

Public-law institution jointly founded by the federal states and the Federation

European Technical Assessment Body
for construction products



European Technical Assessment

ETA-11/0190
of 22 January 2026

English translation prepared by DIBt - Original version in German language

General Part

Technical Assessment Body issuing the European Technical Assessment:

Deutsches Institut für Bautechnik

Trade name of the construction product

Würth self-tapping screws

Product family
to which the construction product belongs

Self-tapping screws for use in timber constructions

Manufacturer

Adolf Würth GmbH & Co. KG
Reinhold-Würth-Straße 12-17
74653 Künzelsau
DEUTSCHLAND

Manufacturing plant

Plants 1 to 20

This European Technical Assessment
contains

88 pages including 9 annexes which form an integral part
of this assessment

This European Technical Assessment is
issued in accordance with Article 95(4) of
Regulation (EU) No 2024/3110, on the basis of

EAD 130118-01-0603

This version replaces

ETA-11/0190 issued on 23 July 2018

The European Technical Assessment is issued by the Technical Assessment Body in its official language. Translations of this European Technical Assessment in other languages shall fully correspond to the original issued document and shall be identified as such.

Communication of this European Technical Assessment, including transmission by electronic means, shall be in full. However, partial reproduction may only be made with the written consent of the issuing Technical Assessment Body. Any partial reproduction shall be identified as such.

This European Technical Assessment may be withdrawn by the issuing Technical Assessment Body, in particular pursuant to information by the Commission in accordance with Article 36(3) of Regulation (EU) No 2024/3110.

Specific part

1 Technical description of the product

Würth "ASSY", "ASSY plus VG", "ASSY VGN", "ASSY Isotop", "ASSY UHP", "ASSY 3.0 / plus MDF" "Jamo" and "WG Fix" screws are self-tapping screws made from special carbon or stainless steel. Screws made from carbon steel are hardened, except "ASSY Isotop" screws. They are anti-friction coated and they have a corrosion protection according to Annex A.2.6. The outer thread diameter d is not less than 3.0 mm and not greater than 14.0 mm. The overall length of the screws is ranging from 13 mm to 2000 mm. Further dimensions are shown in Annex 9. The washers are made from carbon or stainless steel, aluminium or copper. The dimensions of the washers are given in Annex 9.

2 Specification of the intended use in accordance with the applicable European Assessment Document

The performances given in Section 3 are only valid if the screws are used in compliance with the specifications and conditions given in Annex 1 and 2.

The verifications and assessment methods on which this European Technical Assessment is based lead to the assumption of a working life of the screws of at least 50 years. The indications given on the working life cannot be interpreted as a guarantee given by the producer, but are to be regarded only as a means for choosing the right products in relation to the expected economically reasonable working life of the works.

3 Performance of the product and references to the methods used for its assessment

3.1 Mechanical resistance and stability (BWR 1)

Essential characteristic	Performance
Dimensions	See Annex 9
Characteristic yield moment	See Annex 2
Characteristic withdrawal parameter	See Annex 2
Characteristic head pull-through parameter	See Annex 2
Characteristic tensile strength	See Annex 2
Characteristic yield strength	See Annex 2
Characteristic torsional strength	See Annex 2
Insertion moment	See Annex 2
Spacing, end and edge distances of the screws and minimum thickness of the wood-based material	See Annex 2
Slip modulus for mainly axially loaded screws	See Annex 2

3.2 Safety in case of fire (BWR 2)

Essential characteristic	Performance
Reaction to fire	Class A1

3.3 Safety and accessibility in use (BWR 4)

Same as BWR 1

4 Assessment and verification of constancy of performance (AVCP) system applied, with reference to its legal base

In accordance with EAD No. 130118-01-0603 the applicable European legal act is: 97/176/EC.
The system to be applied is: 3

5 Technical details necessary for the implementation of the AVCP system, as provided for in the applicable EAD

Technical details necessary for the implementation of the AVCP system are laid down in the control plan deposited with Deutsches Institut für Bautechnik.

Issued in Berlin on 22 January 2026 by Deutsches Institut für Bautechnik

Anja Dewitt
Head of Section

beglaubigt:
Stützer

English translation prepared by DIBt

Annexes

A.1 Specifications of intended use6

A.1.1 General6

A.1.2 Base materials6

A.1.3 Use Conditions (environmental conditions).....7

A.1.4 Installation provisions.....7

A.2 Characteristic values of the load-carrying capacities10

A.2.1 General10

A.2.2 Laterally loaded screws.....13

A.2.3 Axially loaded screws.....16

A.2.4 Spacing, end and edge distances of the screws and minimum thickness of the wood and gypsum-based material23

A.2.5 Insertion moment42

A.2.6 Durability against corrosion.....42

A.3 Compression reinforcement perpendicular to the grain (informative)43

A.3.1 General43

A.3.2 Design.....43

A.4 Tensile reinforcement perpendicular to grain (informative).....46

A.4.1 General46

A.4.2 Design.....46

A.5 Shear reinforcement (informative)49

A.5.1 General49

A.5.2 Design.....50

A.6 Reinforcement of connections with laterally loaded dowel-type fasteners (informative)52

A.7 Fastening of thermal insulation material on top of rafters (informative).....53

A.7.1 General53

A.7.2 Parallel inclined screws and thermal insulation material in compression.....53

A.7.3 Alternately inclined screws and thermal insulation material non in compression.....58

A.8 Effective number of screws (informative).....62

A.8.1 Effective number of screws under axial stress.....62

A.8.2 Effective number of screws arranged under an angle between the shear plane and the screw axis63

A.9 Dimensions64

A.9.1 General64

A.9.2 Screw head68

A.9.3 Screw shaft and end mill79

A.9.4 Screw threads80

A.9.5 Screw tip84

A.9.6 Bolt marking85

A.9.7 Countersunk and washers86

Würth self-tapping screws	Annex A.0
Table of Contents	

English translation prepared by DIBt

Annexes

A.1 Specifications of intended use

A.1.1 General

Use of the Würth screws only for:

- Static and quasi-static loads

A.1.2 Base materials

The screws are used for connections in load bearing timber structures between wood-based members or between those members and steel or aluminium¹ members:

- Solid timber (softwood) according to EN 14081-1²,
- Solid timber of beech, ash or oak according to EN 14081-1,
- Glued laminated timber (softwood) according to EN 14080³,
- Glued laminated timber made of beech, ash or oak according to European Technical Assessment,
- Laminated veneer lumber LVL of softwood according to EN 14374⁴,
- Laminated veneer lumber LVL of softwood – I-beam flanges in accordance with European Technical Assessments based on EAD 130367-00-0304⁵
- Glued laminated veneer lumber made of beech according to ETA 14/0354,
- Glued solid timber (softwood) according to EN 14080,
- Cross-laminated timber (softwood) according to European Technical Assessment,
- Oriented Strand Board, OSB/3 and OSB/4 according to EN 300⁶ and EN 13986⁷ with $\rho_k \geq 550 \text{ kg/m}^3$,
- Particleboard according to EN 312⁸ and EN 13986 with $\rho_k \geq 640 \text{ kg/m}^3$,
- Solid-wood panels according to EN 13353⁹ and EN 13986
- Gypsum plasterboards for load-bearing applications according to European Technical Assessment with $\rho \geq 650 \text{ kg/m}^3$,
- fermacell[®] Gypsum fibre boards according to ETA-03/0050.

¹ The information given for aluminium members is not based on an assessment according to the provisions of the EAD which is used as basis for the issuing of this ETA and is, thus, also not based on an agreement within EOTA. It is not linked to any provision of Regulation (EU) 2024/3110 of the European Parliament and of the Council of 27 November 2024 laying down harmonised rules for the marketing of construction products and repealing Regulation (EU) No 305/2011 and cannot be used when drawing up a declaration of performance and conformity according to this Regulation.

²	EN 14081-1:2005+A1:2011	Timber structures – Strength graded structural timber with rectangular cross section – Part 1: General requirements
³	EN 14080:2013	Timber structures - Glued laminated timber and glued solid timber - Requirements
⁴	EN 14374:2004	Timber structures - Structural laminated veneer lumber - Requirements
⁵	EAD 130367-00-0304	Composite Wood-Based Beams and Columns
⁶	EN 300:2006	Oriented strand boards (OSB) – Definition, classification and specifications
⁷	EN 13986:2004+A1:2015	Wood-based panels for use in construction - Characteristics, evaluation of conformity and marking
⁸	EN 312:2010	Particleboards - Specifications
⁹	EN 13353:2022-09	Solid wood panels (SWP) – Requirements

Würth self-tapping screws	Annex A.1
Specifications of intended use	

English translation prepared by DIBt

The screws may be used for connecting the following wood-based panels to the timber members mentioned above:

- Plywood according to EN 636¹⁰ and EN 13986,
- Oriented Strand Board, OSB according to EN 300 and EN 13986,
- Particleboard according to EN 312 and EN 13986,
- Fibreboards according to EN 622-2¹¹, EN 622-3¹² and EN 13986,
- Cement-bonded particle boards according to EN 634-2¹³ and EN 13986,
- Solid-wood panels according to EN 13353 and EN 13986.

Wood-based panels (except OSB, particleboards and solid-wood panels) and steel members shall only be arranged on the side of the screw head.

If in a European Technical Assessment according to EAD 130186-00-0603 screws according to EN 14592 are specified to connect three-dimensional nailing plates, Würth screws according to ETA-11/0190 may be considered equivalent, provided that the assumptions regarding the screws in the ETA according to EAD 130186-00-0603 are met.

Würth "ASSY plus VG" and "ASSY" screws with full thread may be used for reinforcing of timber structures perpendicular to the grain. Würth "ASSY plus VG" screws and fully threaded "ASSY" screws with an outer thread diameter of at least 8 mm may also be used for shear reinforcement.

Würth screws with an outer thread diameter of at least 6 mm may be used for the fixing of thermal insulation material on top of rafters or on wood-based members in vertical façades.

A.1.3 Use Conditions (environmental conditions)

The corrosion protection of the Würth screws is specified in Annex A.2.6. With regards to the use and the environmental conditions, the national provisions of the place of installation apply.

A.1.4 Installation provisions

EN 1995-1-1¹⁴ applies for the installation.

A minimum of two screws shall be used for connections in load-bearing timber structures. When fixing boards, battens or intermediate connections of wind braces only one screw may be used. This also applies for the fixing of rafters, purlins or similar on main beams or top plates, if the member is fixed with at least two screws in total.

Only one screw may be used in structural connections when the minimum penetration length of the screw is $20 \cdot d$ and the screw is systematic axially loaded. In the case the screw is used to connect wood-based members the load-bearing capacity of the screw shall be reduced by 50%. If the screw is used as tensile or compressive reinforcement of timber structures perpendicular to the grain no reduction of the load-bearing capacity of the screw is necessary.

The screws are either driven into the wood-based member made of softwood without pre-drilling or in pre-drilled holes with a diameter according to Table A.1.1.

The screws are driven into wood-based members made of beech, ash or oak except LVL made of beech according to EN 14374 or GLVL according to ETA 14/0354 in pre-drilled holes with a diameter according to Table A.1.1.

<p>¹⁰ EN 636:2012+A1:2015 ¹¹ EN 622-2:2004 ¹² EN 622-3:2004 ¹³ EN 634-2:2007 ¹⁴ EN 1995-1-1: 2004+AC:2006+A1:2008+A2:2014</p>	<p>Plywood – Specifications Fibreboards – Specifications – Part 2: Requirements for hardboards Fibreboards – Specifications – Part 3: Requirements for medium boards Cement-bonded particleboards – Specifications – Part 2: Requirements for OPC bonded particleboards for use in dry, humid and external conditions Eurocode 5: Design of timber structures – Part 1-1: General - Common rules and rules for buildings</p>
--	--

Würth self-tapping screws	Annex A.1
Specifications of intended use	

English translation prepared by DIBt

Table A.1.1 Diameter of the pre-drilled holes in softwood and in beech, ash or oak and in Aluminium-wood-connections

Outer thread diameter [mm]	Diameter of the pre-drilled hole with a tolerance of ± 0.1 mm [mm]			
	Wood-based member of softwood	Wood-based members made of beech, ash or oak	Wood-based members made of beech LVL or GLVL	Aluminium-wood connections with "ASSY" plus VG screws
3.0 / 3.4	1.5	2.0	—	—
3.5 / 3.9	2.0	2.5	—	—
4.0 / 4.4	2.5	3.0	3.0	—
4.5	2.5	3.5	3.5	—
5.0	3.0	3.5	4.0	—
5.5 / 6.0 / 6.3	4.0	4.0	4.5	5.0
6.5 / 7.0	4.0	5.0	5.5	—
8.0	5.0	6.0	6.5	6.0
10.0	6.0	7.0	8.0	8.0
12.0	7.0	8.0	9.0	9.0
14.0	8.0	9.0	11.0	—

The penetration length of the threaded part of Würth "ASSY" and "Jamo" carbon steel screws, which are driven with or without pre-drilling into members made of laminated veneer lumber (LVL) from softwood or beech according to EN 14374, or GLVL according to ETA 14/0354, shall not exceed the values given in Table A.1.2.

Table A.1.2 Maximum penetration length of the threaded part of carbon steel screws driven, with or without pre-drilling, into members made of laminated veneer lumber (LVL) from softwood or beech according to EN 14374, or GLVL according to ETA 14/0354.

Outer thread diameter [mm]	Maximum penetration length of the threaded part of the screws [mm]				
	With pre-drilling in		Without pre-drilling in		
	Laminated veneer lumber (LVL) made of beech or in GLVL according to ETA 14/0354		Laminated veneer lumber (LVL) made of softwood	Laminated veneer lumber (LVL) made of beech or GLVL according to ETA 14/0354	
	"ASSY plus" und "Jamo plus" screws	Aluminium-wood connections with "ASSY" plus full-thread screws	"ASSY" and "Jamo" screws without drill tip	"ASSY plus" and "Jamo plus" screws	"ASSY" and "Jamo" screws without drill tip
5.0	Thread length	—	—	—	50
6.0	Thread length	180	—	30	60
7.0	Thread length	—	—	—	70
8.0	200	180	260 (UHP: 300)	48	80 (UHP: 250)
10.0	260	180	300	80	100
12.0	Thread length	220	600	96	—

Würth self-tapping screws	Annex A.1
Specifications of intended use	

English translation prepared by DIBt

The penetration length of the threaded part of Würth “ASSY” and “Jamo” carbon steel screws, which are driven without pre-drilling into members made of OSB/3, OSB/4 boards and particleboards, shall not exceed the values given in Table A.1.3.

Table A.1.3 Maximum penetration length of the threaded part of the screws without pre-drilling in OSB/3, OSB/4 boards and particleboards [mm]

Outer thread diameter [mm]	OSB/3, OSB/4 boards and particleboards	
	“ASSY plus” and “Jamo plus” screws	“ASSY” and “Jamo” screws without drill tip
5.0	—	50
6.0	30	50
7.0	—	50
8.0	50	50
10.0	50	50
12.0	50	50

The maximum penetration length of the “WG Fix” screws in gypsum fibre boards boards is 20,0 mm and of the gypsum plasterboards 25,0 mm.

The screw holes in steel members shall be executed in such a way that the screw threads do not come into contact with the steel member. In addition, a precise seating of the screw head in or on the steel member shall be ensured, for example by providing an appropriate countersink when using countersunk screws.

Würth screws with an outer thread diameter of $d = 14$ mm and a length $l \geq 800$ mm shall only be driven in softwood in a guiding hole with a diameter of 8 mm and a minimum length of 10% of the screw length.

If screws with an outer thread diameter $d \geq 8$ mm are driven into the wood-based member without pre-drilling, the structural solid or glued laminated timber, laminated veneer lumber and similar glued members shall be from spruce, pine, fir or beech (only LVL or GLVL).

In the case of fastening battens on thermal insulation material on top of rafters the screws shall be driven in the rafter through the battens and the thermal insulation material without pre-drilling in one sequence.

Screws may be used with appropriate washers according to Annex A.9.7. After inserting the screw, the washers shall touch the surface of the wood-based member completely.

By fastening screws in wood-based members the head of the screws shall be flush with the surface of the wood-based member. For pan head, top head, back panel head, Elmo-head, large washer head, joist hanger screw head, kombi hexagonal head, truss head, hexagonal head and hexalobular head the head part remains unconsidered.

For combined pre-drilling of aluminium-wood connections, the drill hole diameter is specified in Table A.1.1, and the maximum penetration length of the “ASSY plus” full-thread screws is given in Table A.1.2. When aluminium-wood connections are pre-drilled in one step, the timber members shall be made of softwood with a characteristic density $\rho_k \leq 500$ kg/m³. The tensile strength of the aluminium, R_m , shall not exceed 250 N/mm², and the connection may contain a maximum of two aluminium plates. For screw diameters of 6 mm and 8 mm, the aluminium sheet thickness is limited to 6 mm, and for diameters of 10 mm and 12 mm, to a thickness of 8 mm.

Würth self-tapping screws	Annex A.1
Specifications of intended use	

English translation prepared by DIBt

A.2 Characteristic values of the load-carrying capacities

A.2.1 General

The characteristic values listed in Table A.2.1, Table A.2.2 and Table A.2.3 apply only to the outer thread diameters of the screws specified in these Tables.

Table A.2.1 Characteristic load-carrying capacities of Würth self-tapping screws made from carbon steel with $d = 3.0$ mm to 6.0 mm

Outer thread diameter [mm]		3.0	3.4	3.5	3.9	4.0	4.4	4.5	5.0	6.0
Characteristic yield moment $M_{y,k}$ [Nm]	ASSY plus VG	—	—	—	—	—	—	—	—	9.0
	ASSY 3.0 / plus MDF	—	1.7	—	1.9	—	3.0	—	—	—
	Remaining screws	1.6	—	1.8	—	3.3	—	3.7	5.9	10.0
Characteristic tensile strength $f_{tens,k}$ [kN]	ASSY plus VG	—	—	—	—	—	—	—	—	11.5
	ASSY 3.0 / plus MDF	—	2.8	—	3.9	—	5.0	—	—	—
	Remaining screws	2.8	—	3.0	—	5.0	—	5.3	7.9	12.5
Characteristic torsional strength $f_{tor,k}$ [Nm]	ASSY plus VG	—	—	—	—	—	—	—	—	10.5
	ASSY 3.0 / plus MDF	—	1.5	—	1.9	—	3.0	—	—	—
	Remaining screws	1.5	—	2.0	—	3.0	—	4.3	6.0	10.0

Würth self-tapping screws	Annex A.2
Characteristic values of the load-carrying capacities	

English translation prepared by DIBt

Table A.2.2 Characteristic load-carrying capacities of Würth self-tapping screws made from carbon steel with d = 6.3 mm to 14.0 mm

Outer thread diameter [mm]		6.3	7.0	8.0	10.0	12.0	14.0
Characteristic yield moment $M_{y,k}$ [Nm]	ASSY plus VG and ASSY VGN	—	—	23.0	40.0	62.0	86.0
	ASSY plus VG (hot-dip galvanised)	—	—	—	—	—	86.0
	ASSY Isotop 8.0 / 10.0	—	—	11.0	—	—	—
	ASSY UHP	—	—	39.0	—	—	—
	WG Fix	6.5	—	—	—	—	—
	Remaining screws	—	14.0	23.0	36.0	58.0	—
Characteristic tensile strength $f_{tens,k}$ [kN]	ASSY plus VG and ASSY VGN	—	—	22.0	33.0	47.0	62.0
	ASSY plus VG Hot-dip galvanised	—	—	—	—	—	47.0
	ASSY Isotop 8.0 / 10.0	—	—	11.0	—	—	—
	ASSY UHP	—	—	30.0	—	—	—
	WG Fix	8.0	—	—	—	—	—
	Remaining screws	—	15.0	21.5	26.0	41.0	-
Characteristic torsional strength $f_{tor,k}$ [Nm]	ASSY plus VG and ASSY VGN	—	—	25.0	47.0	76.0	115
	ASSY plus VG Hot-dip galvanised	—	—	—	—	—	100
	ASSY Isotop 8.0 / 10.0	—	—	20 ^{a)}	—	—	—
				12 ^{b)}			
	ASSY UHP	—	—	38.0	—	—	—
	WG Fix	8.0	—	—	—	—	—
Remaining screws	—	15.0	23.0	45.0	65.0	—	
a) Head side							
b) Point side							

Würth self-tapping screws	Annex A.2
Characteristic values of the load-carrying capacities	

English translation prepared by DIBt

Table A.2.3 Characteristic load-carrying capacities of Würth self-tapping screws made from stainless steel

Outer thread diameter [mm]		3.0	3.5	4.0	4.5	5.0	5.5 ^{a)}	5.5 ^{b)}	6.0	6.5	8.0	10.0
Characteristic yield moment $M_{y,k}$ [Nm]		0.9	1.4	1.9	2.3	2.8	4.4	5.2	5.5	6.8	11.0	20.0
Characteristic tensile strength $f_{tens,k}$ [kN]		1.8	2.4	3.1	3.6	5.2	7.0	6.5	8.2	8.3	14.0	19.0
Characteristic torsional strength $f_{tor,k}$ [Nm]	Head side ASSY P screws	—	2.7	—	3.6	—	5.2	5.2	—	—	—	—
	Rooftop PV screw	—	—	—	—	—	—	—	—	—	17.5	—
	Point side remaining screws	0.85	1.35	2.0	2.6	4.0	5.2	5.2	7.3	7.5	17.0	30.0
a) Screws other than Würth ASSY 4 A2 P b) Würth ASSY 4 A2 P screws												

The minimum penetration length of the threaded part of the screw in the wood-based members l_{ef} shall be

$$l_{ef} = \min \left\{ \begin{array}{l} \frac{4 \cdot d}{\sin \alpha} \\ 20 \cdot d \end{array} \right. \quad (2.1)$$

where

- α angle between screw axis and grain direction
- d outer thread diameter of the screw.

When fastening battens on thermal insulation material on top of rafters the minimum penetration length of the threaded part of the screw in the wood-based members l_{ef} shall be 40 mm, in case of flanges made from LVL 30 mm.

The outer thread diameter of screws inserted in cross-laminated timber shall be at least 6 mm. The inner thread diameter d_1 of the screws shall be greater than the maximal width of the gaps in the layer of cross laminated timber. Reductions in the cross-sectional area caused of wood-based members by Würth screws with a diameter of 10 mm or more shall be taken into account in the member strength verification both, in the tensile and compressive area of members. For screws in pre-drilled holes, the drill hole diameter should be considered in the member strength verification, for screws driven without pre-drilling, the inner thread diameter d_1 .

Würth self-tapping screws	Annex A.2
Characteristic values of the load-carrying capacities	

English translation prepared by DIBt

A.2.2 Laterally loaded screws¹⁵

A.2.2.1 General

The outer thread diameter d shall be used as effective diameter of the screw according to EN 1995-1-1.

The embedding strength for the screws in wood-based members or in wood-based panels shall be taken from EN 1995-1-1 unless otherwise specified in the following.

For steel-to-timber connections with screws $d = 5$ mm with joist hanger screw head, a thick steel plate may be assumed for steel plate thickness $t \geq 1,5$ mm.

For laterally loaded screws, the rules for multiple fastener connections in EN 1995-1-1, 8.3.1.1 (8) should be applied, if the timber under each fastener in a connection is not reinforced according to Annex A.6.

A.2.2.2 Solid timber, glued laminated timber, glued solid timber and solid wood panels

The embedding strength for screws in non-pre-drilled holes in softwood arranged at an angle between screw axis and grain direction of $0^\circ \leq \alpha \leq 90^\circ$ is:

$$f_{h,k} = \frac{0.082 \cdot \rho_k \cdot d^{-0.3}}{2.5 \cdot \cos^2 \alpha + \sin^2 \alpha} \quad [\text{N/mm}^2] \quad (2.2)$$

The embedding strength for screws in pre-drilled holes in softwood or in ash, beech or oak hardwood arranged at an angle between screw axis and grain direction of $0^\circ \leq \alpha \leq 90^\circ$ is:

$$f_{h,k} = \frac{0.082 \cdot \rho_k \cdot (1 - 0.01 \cdot d)}{2.5 \cdot \cos^2 \alpha + \sin^2 \alpha} \quad [\text{N/mm}^2] \quad (2.3)$$

where

- ρ_k Characteristic density of the wood-based member [kg/m^3], for beech, ash and oak $\rho_k \leq 590 \text{ kg/m}^3$
- d Outer thread diameter of the screw [mm]
- α Angle between screw axis and grain direction, $0^\circ \leq \alpha \leq 90^\circ$.

A.2.2.3 Laminated veneer lumber

The embedding strength for screws in non-pre-drilled holes in softwood LVL arranged at an angle between screw axis and grain direction, $0^\circ \leq \alpha \leq 90^\circ$ is:

$$f_{h,k} = \frac{0.082 \cdot \rho_k \cdot d^{-0.3}}{(2.5 \cdot \cos^2 \alpha + \sin^2 \alpha)(1.5 \cdot \cos^2 \beta + \sin^2 \beta)} \quad [\text{N/mm}^2] \quad (2.4)$$

¹⁵ The information given in this Annex is not based on an assessment according to the provisions of the EAD which is used as basis for the issuing of this ETA and is, thus, also not based on an agreement within EOTA. It is not linked to any provision of Regulation (EU) 2024/3110 of the European Parliament and of the Council of 27 November 2024 laying down harmonised rules for the marketing of construction products and repealing Regulation (EU) No 305/2011 and cannot be used when drawing up a declaration of performance and conformity according to this Regulation.

Würth self-tapping screws	Annex A.2
Characteristic values of the load-carrying capacities	

English translation prepared by DIBt

and accordingly for screws in pre-drilled holes in softwood LVL arranged at an angle between screw axis and grain direction, $0^\circ \leq \alpha \leq 90^\circ$:

$$f_{h,k} = \frac{0.082 \cdot \rho_k \cdot (1 - 0.01 \cdot d)}{(2.5 \cdot \cos^2 \alpha + \sin^2 \alpha)(1.5 \cdot \cos^2 \beta + \sin^2 \beta)} \quad [\text{N/mm}^2] \quad (2.5)$$

where

ρ_k characteristic timber density of the softwood LVL [kg/m^3], $\rho_k \leq 500 \text{ kg/m}^3$,

d outer thread diameter of the screw [mm],

α angle between screw axis and grain direction ($0^\circ \leq \alpha \leq 90^\circ$),

β angle between screw axis and the LVL's wide face ($0^\circ \leq \beta \leq 90^\circ$).

The embedding strength for screws in pre-drilled or non-pre-drilled holes in Beech LVL according to EN 14374 or in GLVL according to ETA-14/0354 arranged at an angle between screw axis and grain direction, $0^\circ \leq \alpha \leq 90^\circ$ is:

$$f_{h,k} = \frac{0.082 \cdot \rho_k \cdot d^{-0.15}}{(2.5 \cdot \cos^2 \alpha + \sin^2 \alpha) \cdot k_\varepsilon \cdot k_\beta} \quad [\text{N/mm}^2] \quad (2.6)$$

where

ρ_k characteristic density of Beech LVL or GLVL [kg/m^3], $\rho_k \leq 730 \text{ kg/m}^3$

d outer thread diameter of the screw [mm],

α angle between screw axis and grain direction, $0^\circ \leq \alpha \leq 90^\circ$,

$$k_\varepsilon = (0.5 + 0.024 \cdot d) \cdot \sin^2 \varepsilon + \cos^2 \varepsilon, \quad (2.7)$$

ε angle between load and grain direction, $0^\circ \leq \varepsilon \leq 90^\circ$,

$$k_\beta = 1.2 \cdot \cos^2 \beta + \sin^2 \beta, \quad (2.8)$$

β angle between screw axis and wide face of LVL or GLVL member, $0^\circ \leq \beta \leq 90^\circ$.

Würth self-tapping screws	Annex A.2
Characteristic values of the load-carrying capacities	

English translation prepared by DIBt

A.2.2.4 Cross laminated timber

The embedding strengths according to equations (2.2) and (2.3) may be applied for screws within single softwood layers in cross laminated timber, if the single layer is considered as a separate softwood member and the minimum spacing, end and edge distances are observed for the single layer. For inner layers, the edge distance perpendicular to the grain may be reduced to $3 \cdot d$.

Alternatively, the embedding strength for screws arranged in the edge surfaces parallel to the plane of cross laminated timber may be assumed according to equation (2.9) independent of the angle between screw axis and grain direction, $0^\circ \leq \alpha \leq 90^\circ$:

$$f_{h,k} = 20 \cdot d^{-0.5} \quad [\text{N/mm}^2] \quad (2.9)$$

unless otherwise specified in the technical specification of the cross laminated timber.

Where d is the outer thread diameter of the screws in mm.

Equation (2.9) is only valid for softwood layers. The provisions in the European Technical Assessment of the cross laminated timber apply.

The embedding strength for screws in the wide face of cross laminated timber may be assumed as for solid timber based on the characteristic density of the outer layer. Where applicable, the angle between force and grain direction of the outer layer shall be taken into account. The direction of the lateral force shall be perpendicular to the screw axis and parallel to the wide face of the cross laminated timber.

Würth self-tapping screws	Annex A.2
Characteristic values of the load-carrying capacities	

English translation prepared by DIBt

A.2.3 Axially loaded screws

A.2.3.1 Axial slip modulus

The axial slip modulus K_{ser} of the threaded part of a screw for the serviceability limit state shall be taken independent of angle α to the grain as:

$$K_{ser} = 1250 \cdot d^{0.2} \cdot l_{ef}^{0.4} \cdot \rho_m^{0.2} \quad [\text{N/mm}] \text{ for screws in members made of softwood} \quad (2.10)$$

$$K_{ser} = 30 \cdot d \cdot l_{ef} \quad [\text{N/mm}] \text{ for screws in members made of hardwood} \quad (2.11)$$

where

d outer thread diameter of the screw [mm]

l_{ef} penetration length of the of the threaded part of the screw in the wood-based member [mm]

ρ_m mean density of the wood-based member [kg/m³].

A.2.3.2 Axial withdrawal capacity¹⁶

The characteristic withdrawal capacity in solid timber (softwood or hardwood species beech, ash and oak with $\rho_k \leq 590 \text{ kg/m}^3$), glued laminated timber (softwood or hardwood species beech, ash and oak with $\rho_k \leq 590 \text{ kg/m}^3$), cross laminated timber, solid wood panels or laminated veneer lumber members or GLVL according to ETA-14/0354 with $\rho_k \leq 750 \text{ kg/m}^3$ at an angle of $0^\circ \leq \alpha \leq 90^\circ$ to the grain shall be calculated as:

$$F_{ax,\alpha,Rk} = \frac{n_{ef} \cdot k_{ax} \cdot f_{ax,k} \cdot d \cdot l_{ef}}{k_\beta} \cdot \left(\frac{\rho_k}{\rho_a}\right)^{0.8} \quad [\text{N}] \quad (2.12)$$

where

$F_{ax,\alpha,Rk}$ characteristic withdrawal capacity of a screw group at an angle α to the grain [N]

n_{ef} effective number of screws according to Table A.8.1.

For screws as compression reinforcement or inclined screws as fasteners in mechanically jointed beams or columns or for the fixing of thermal insulation material, $n_{ef} = n$.

n number of screws acting together in a connection

For inclined screws is n the number of crossed pairs of screws.

k_{ax} Factor, taking into account the angle α between screw axis and grain direction

$$k_{ax} = 1.0 \quad \text{for } 30^\circ \leq \alpha \leq 90^\circ$$

$$k_{ax} = 0.8 \text{ for LVL flanges of I-beams for } 45^\circ \leq \alpha \leq 90^\circ$$

$$k_{ax} = a + \frac{b \cdot \alpha}{30^\circ} \quad \text{for } 0^\circ \leq \alpha < 30^\circ \text{ (not valid for flanges of I-beams)} \quad (2.13)$$

¹⁶ Only the information on $f_{ax,k}$ in this section is covered by the EAD. Further information given in this Annex are not based on an assessment according to the provisions of the EAD which is used as basis for the issuing of this ETA and is, thus, also not based on an agreement within EOTA. It is not linked to any provision of Regulation (EU) No. 2024/3110 of the European Parliament and of the Council of 27 November 2024 laying down harmonised rules for the marketing of construction products and repealing Regulation (EU) No 305/2011 and cannot be used when drawing up a declaration of performance and conformity according to this Regulation.

Würth self-tapping screws	Annex A.2
Characteristic values of the load-carrying capacities	

English translation prepared by DIBt

$$a = \begin{cases} 0.5 & \text{for laminated veneer lumber, including LVL and GLVL, in accordance with ETA-14/0354} \\ 0.3 & \text{for solid timber, glued solid timber, glued laminated timber, CLT and solid wood panels} \end{cases}$$

$$b = \begin{cases} 0.5 & \text{for LVL} \\ 0.7 & \text{for solid timber, glued solid timber, glued laminated timber, CLT and solid wood panels} \end{cases}$$

$$\text{If } l_{ef} \geq \min \begin{cases} \frac{4 \cdot d}{\sin \alpha} \\ 20 \cdot d \end{cases} \quad \text{and } \alpha \geq 15^\circ \rightarrow k_{ax} \text{ may alternatively be taken as} \quad (2.14)$$

$$k_{ax} = \frac{1}{1.2 \cdot \cos^2 \alpha + \sin^2 \alpha} \quad (2.15)$$

$$k_\beta = \begin{cases} k_\beta = 1.0 & \text{for solid timber, glued solid timber, glued laminated timber and solid wood panels} \\ k_\beta = 1.5 \cdot \cos^2 \beta + \sin^2 \beta & \text{for laminated veneer lumber} \end{cases} \quad (2.16)$$

$f_{ax,k}$ Characteristic withdrawal parameter for

- solid timber, glued laminated timber, cross laminated timber, solid wood panels and laminated veneer lumber members with a maximum characteristic density of 590 kg/m³ and $\rho_a = 350$ kg/m³ → see Table A.2.4
- Beech LVL or GLVL (ETA-14/0354) members with a density of 590 kg/m³ ≤ ρ_k ≤ 750 kg/m³ and $\rho_a = 730$ kg/m³:
 $f_{ax,k} = 35.0$ N/mm² for screws with 5.0 mm ≤ d ≤ 12.0 mm
- OSB/3, OSB/4 boards with $\rho_k \geq 550$ kg/m³ and particleboards with $\rho_k \geq 640$ kg/m³ and $\rho_a = \rho_k$:
 $f_{ax,k} = 7.0$ N/mm² for screws with 4.0 mm ≤ d ≤ 6.0 mm
The thickness of the OSB/3, OSB/4 boards shall be at least 12 mm and of the particleboards at least 13 mm, whereby the screw tip shall not be considered.
- Gypsum fibre boards (ETA-03/0050) and gypsum plasterboards with $\rho_k \geq 650$ kg/m³ and $\rho_a = \rho_k$:
 $f_{ax,k} = 7.0$ N/mm² for "WG Fix" screws in gypsum fibre boards
 $f_{ax,k} = 2.0$ N/mm² for "WG Fix" screws in gypsum plasterboards
The thickness of the Gypsum fibre boards boards shall be at least 10 mm and of the gypsum plasterboards at least 12.5 mm, whereby the screw tip shall not be considered.

d outer thread diameter of the screw [mm]

l_{ef} penetration length of the threaded part of the screw [mm]

α angle between grain and screw axis ($0^\circ \leq \alpha \leq 90^\circ$)

β angle between screw axis and the LVL's wide face ($0^\circ \leq \beta \leq 90^\circ$)

ρ_k characteristic density of the wood-based member or of the gypsum fibre boards or plasterboards [kg/m³]

ρ_a associated density for $f_{ax,k}$ [kg/m³]

Würth self-tapping screws	Annex A.2
Characteristic values of the load-carrying capacities	

English translation prepared by DIBt

Table A.2.4 Characteristic withdrawal parameter for different types of screws for solid timber, glued laminated timber, cross laminated timber, solid wood panels and laminated veneer lumber members with $\rho_k \leq 590 \text{ kg/m}^3$ and $\rho_a = 350 \text{ kg/m}^3$

d [mm]	$f_{ax,k}$ [N/mm ²]	Screw type
$3.0 \leq d \leq 7.0$	13.0	ASSY 4
8.0	12.0	ASSY 4
10.0	11.5	ASSY 4
12.0	11.0	ASSY 4
6.0	11.5	ASSY 4 VG
8.0	12.0	ASSY 4 VG und ASSY 4 VGN
10.0	11.5	ASSY 4 VG und ASSY 4 VGN
12.0	11.0	ASSY 4 VG und ASSY 4 VGN
14.0	10.0	ASSY 4 VG
—	11.5	ASSY Isotop
—	11.0	ASSY plus MDF
—	10.0	WG Fix
—	12.0	ASSY UHP
$3.0 \leq d \leq 5.0$	12.0	Other screws
$5.5 \leq d \leq 7.0$	11.5	Other screws
$7.5 \leq d \leq 10.0$	11.0	Other screws
> 10.0	10.0	Other screws

The characteristic withdrawal parameter is also valid for softwood layers of cross-laminated timber.

For screws penetrating more than one layer of cross laminated timber the different layers may be taken into account proportionally. In the lateral surfaces of the cross laminated timber the screws shall be fully inserted in one layer of cross-laminated timber.

Alternatively, the axial withdrawal capacity for screws arranged parallel to the plane of cross laminated timber, independent of the angle between screw axis and grain direction, $0^\circ \leq \alpha \leq 90^\circ$, may be calculated from:

$$F_{ax,Rk} = 20 \cdot d^{0.8} \cdot l_{ef}^{0.9} \quad [\text{N}] \quad (2.17)$$

where

d outer thread diameter [mm]

l_{ef} penetration length of the threaded part of the screw [mm]

For beech, ash and oak wood except Beech LVL and GLVL (ETA-14/0354) a maximum characteristic density of 590 kg/m^3 shall be used in equation (8.40a) of EN 1995-1-1 and in equation (2.12) of this ETA.

The axial withdrawal capacity is limited by the head pull-through capacity and the tensile or compressive capacity of the screw.

Würth self-tapping screws	Annex A.2
Characteristic values of the load-carrying capacities	

English translation prepared by DIBt

A.2.3.3 Head pull-through capacity

The characteristic value of the head pull-through parameter for the screws for $\rho_a = 350 \text{ kg/m}^3$ of the timber and for wood-based panels like

- Plywood according to EN 636 and EN 13986
- Oriented Strand Board, OSB according to EN 300 and EN 13986
- Particleboard according to EN 312 and EN 13986
- Fibreboards according to EN 622-2, EN 622-3 and EN 13986
- Cement-bonded particle boards according to EN 634-2 and EN 13986,
- Solid-wood panels according to EN 13353 and EN 13986

with a thickness of more than 20 mm is given in Table A.2.5.

Table A.2.5 Characteristic value of the head pull-through parameter

Head pull-through parameter $f_{\text{head},k}$ in N/mm^2	Head shape
$\min \begin{cases} 19.4 - 0.28 \cdot d_h \\ 14.0 \end{cases}$	90° countersunk head
$\min \begin{cases} 28.4 - 0.64 \cdot d_h \\ 15.0 \end{cases}$	180° back plate, washer, or pan head with a head diameter $d_h \leq 30 \text{ mm}$
13.0	all other head shapes and with a head diameter $d_h \leq 19 \text{ mm}$
10.0	all other head shapes and with a head or washer diameter $d_h > 19 \text{ mm}$
15.0	"JAMO" and "JAMO plus" screws
23.0	"ASSY" screws with underhead thread, except for "ASSY" PII $d = 8 \text{ mm}$
18.0	"ASSY" PII $d = 8 \text{ mm}$ with underhead thread
$40 - 0.5 \cdot d_h$	Würth screws with a head or washer diameter $d_h \leq 25 \text{ mm}$ in Beech LVL or GLVL (ETA-14/0354) with a characteristic density of $590 \text{ kg/m}^3 \leq \rho_k \leq 750 \text{ kg/m}^3$ and with a thickness of at least 40 mm
16.0	screws with $d = 8 \text{ mm}$ and washers type E or F with $d_h = 25 \text{ mm}$ in LVL with $\rho_k \leq 590 \text{ kg/m}^3$ for $\rho_a = 500 \text{ kg/m}^3$
32.0	screws with $d = 8 \text{ mm}$ and washers type E or F with $d_h = 25 \text{ mm}$ in Beech LVL or GLVL (ETA 14/0354) with $\rho_k \geq 680 \text{ kg/m}^3$ for $\rho_a = 730 \text{ kg/m}^3$ and with a thickness of at least 40 mm

For wood-based panels a maximum characteristic density of 380 kg/m^3 and for beech, ash and oak wood and LVL made from softwood a maximum characteristic density of 590 kg/m^3 shall be used in equation (8.40b) of EN 1995-1-1. For Beech LVL and GLVL (ETA-14/0354) a maximum characteristic density of 730 kg/m^3 shall be used in equation (8.40b) of EN 1995-1-1.

The head diameter shall be equal to or greater than $1.8 \cdot d_s$, where d_s is the smooth shank or the inner thread diameter. Otherwise the characteristic head pull-through capacity in equation (8.40b) of EN 1995-1-1 is for all wood-based materials: $F_{\text{ax},\alpha,\text{Rk}} = 0$.

Würth self-tapping screws	Annex A.2
Characteristic values of the load-carrying capacities	

English translation prepared by DIBt

For wood-based panels with a thickness $12 \text{ mm} \leq t \leq 20 \text{ mm}$ the characteristic value of the head pull-through parameter for the screws is:

$$f_{\text{head,k}} = 8 \text{ N/mm}^2$$

For wood-based panels with a thickness of less than 12 mm the characteristic head pull-through capacity for screws shall be based on a characteristic value of the head pull-through parameter of 8 N/mm^2 , and limited to 400 N complying with the minimum thickness of the wood-based panels of $1.2 \cdot d$, with d as outer thread diameter and the values in Table A.2.6.

Table A.2.6 Minimum thickness of wood-based panels

Wood based panel	Minimum thickness [mm]
Plywood	6
Fibreboards (hardboards and medium boards)	6
Oriented Strand Boards, OSB	8
Particleboards	8
Cement-bonded particle board	8
Solid wood Panels	12

Outer diameter of washers $d_h > 35 \text{ mm}$ shall not be considered.

For Würth "ASSY plus VG" screws, "ASSY" screws with a full thread and "ASSY" screws with a thread under the head the withdrawal capacity of the thread in the wood-based member with the screw head may be taken into account instead of the head pull-through capacity.

That also applies for screws with a thread over a part of the screw length. The minimum penetration length of the thread of $4 \cdot d$ shall be considered in the timber member near the screw head in this case.

In steel-to-timber connections the head pull-through capacity is not governing.

Würth self-tapping screws	Annex A.2
Characteristic values of the load-carrying capacities	

English translation prepared by DIBt

A.2.3.4 Compressive capacity of Würth "ASSY plus VG" screws and fully threaded "ASSY" screws

The design value of the axial load-carrying capacity $F_{ax,Rd}$ of Würth "ASSY plus VG" full-thread screws under compression is the minimum of the resistance against the screws being pushed through the softwood structural member and the buckling resistance of the screws. The following provisions apply to screws used in solid timber (ST/FST), laminated veneer lumber (LVL, GLVL), glued laminated timber (GLT), glued solid timber (GST), and cross-laminated timber (CLT), for insertion angles between $0^\circ \leq \alpha \leq 90^\circ$.

$$F_{ax,Rd} = \min \begin{cases} f_{ax,d} \cdot d \cdot l_{ef} \\ \kappa_c \cdot N_{pl,d} \end{cases} \quad (2.18)$$

where

$f_{ax,d}$ design value of the axial withdrawal capacity of the threaded part of the screw [N/mm²]

d outer thread diameter of the screw [mm]

l_{ef} penetration length of the threaded part of the screw in the timber member [mm]

$$\kappa_c = 1.0 \quad \text{for } \bar{\lambda}_k \leq 0.2 \quad (2.19)$$

$$\kappa_c = \frac{1}{k + \sqrt{k^2 - \bar{\lambda}_k^2}} \quad \text{for } \bar{\lambda}_k > 0.2 \quad (2.20)$$

where

$$k = 0.5 \cdot [1 + 0.49 \cdot (\bar{\lambda}_k - 0.2) + \bar{\lambda}_k^2] \quad (2.21)$$

and a relative slenderness ratio

$$\bar{\lambda}_k = \sqrt{\frac{N_{pl,k}}{N_{ki,k}}} \quad (2.22)$$

where

$$N_{pl,k} = \frac{\pi}{4} \cdot d_1^2 \cdot f_{y,k} \quad (2.23)$$

$f_{y,k}$ characteristic yield strength

$f_{y,k} = 900$ N/mm² for "ASSY plus VG" and fully threaded "ASSY" screws

$f_{y,k} = 800$ N/mm² for hot-dip galvanised "ASSY" plus VG screw

d_1 inner thread diameter of the screw [mm]

$$N_{pl,d} = \frac{N_{pl,k}}{\gamma_{M1}} \quad (2.24)$$

γ_{M1} partial factor according to EN 1993-1-1

Würth self-tapping screws	Annex A.2
Characteristic values of the load-carrying capacities	

English translation prepared by DIBt

characteristic ideal elastic buckling load in [N]:

$$N_{k_i,k} = \sqrt{c_h \cdot E_s \cdot I_s} \quad (2.25)$$

c_h elastic foundation of the screw in [N/mm²]:

$$c_h = (0.19 + 0.012 \cdot d) \cdot \rho_k \cdot \left(\frac{90^\circ + \alpha}{180^\circ} \right) \quad (2.26)$$

ρ_k characteristic density of the wood-based member [kg/m³]

For hardwood products, a characteristic density $\rho_k = 350 \text{ kg/m}^3$ shall be assumed.

α angle between screw axis and grain direction with $0^\circ \leq \alpha \leq 90^\circ$

E_s modulus of elasticity in [N/mm²]

$$E_s = 210\,000 \text{ N/mm}^2$$

I_s second moment of area in [mm⁴]

$$I_s = \frac{\pi \cdot d_1^4}{64} \quad (2.27)$$

If a fixed embedding of the screw head is assumed, the perpendicular-to-grain bearing capacity of the timber shall not be taken into account.

Würth self-tapping screws	Annex A.2
Characteristic values of the load-carrying capacities	

English translation prepared by DIBt

A.2.4 Spacing, end and edge distances of the screws and minimum thickness of the wood and gypsum-based material

A.2.4.1 General

The spacing and distances for screws are defined as follows.

Symbols according to EN 1995-1-1	Symbols in this ETA	Description
a_1	a_1	Spacing parallel to grain
a_2	a_2	Spacing perpendicular to grain
$a_{3,c}$	$a_{3,c}$	Distance to unloaded end
$a_{3,t}$	$a_{3,t}$	Distance to loaded
$a_{4,c}$	$a_{4,c}$	Distance to unloaded edge
$a_{4,t}$	$a_{4,t}$	Distance to loaded edge
$a_{1,CG}$	$a_{3,CG}$	Minimum end distance of the centre of gravity of the threaded part of the screw in the member
$a_{2,CG}$	$a_{4,CG}$	Minimum edge distance of the centre of gravity of the threaded part of the screw in the member

A.2.4.2 Laterally and / or axially loaded screws

A.2.4.2.1 Screws in pre-drilled holes or "ASSY plus", "ASSY plus VG" and "Jamo plus"¹⁷ screws in non-pre-drilled holes

For Würth screws in pre-drilled holes, for "ASSY plus", "ASSY plus VG" and "Jamo plus" screws also in non-pre-drilled holes in softwood, the minimum spacings, end and edge distances are given in EN 1995-1-1, clause 8.3.1.2 and Table 8.2 as for nails in pre-drilled holes. Here, the outer thread diameter d shall be considered.

Minimum thickness for structural members made from solid timber, glued laminated timber, glued solid timber, laminated veneer lumber and cross laminated timber is $t = 24$ mm for screws with $d < 8$ mm, $t = 30$ mm for screws with $d = 8$ mm, $t = 40$ mm for screws with $d = 10$ mm, $t = 80$ mm for screws with $d = 12$ mm and $t = 100$ mm for screws with $d = 14$ mm.

Minimum thickness for OSB/3, OSB/4 boards is 12 mm and for particle boards 13 mm. The thickness of the boards shall not be greater than 30 mm. The minimum thickness of wood-based panels arranged on the side of the screw head is given in Table A.2.4.

The minimum thickness of gypsum plasterboards is 12.5 mm and for fermacell® Gypsum fibre boards 10 mm.

A.2.4.2.2 Screws in non-pre-drilled holes

For Würth screws except for "ASSY plus" "ASSY plus VG" and "Jamo plus" screws in non-pre-drilled holes minimum spacing and distances are given in EN 1995-1-1, clause 8.3.1.2 and Table 8.2 as for nails in non-pre-drilled holes. Minimum spacing and distances according to EN 1995-1-1, clause 8.3.1.2 and Table 8.2 for nails in non-pre-drilled holes and a characteristic density of $420 \text{ kg/m}^3 \leq \rho_k \leq 500 \text{ kg/m}^3$ also apply for "ASSY" and "Jamo" screws made from carbon steel with $5 \text{ mm} \leq d \leq 12 \text{ mm}$ in Beech LVL and GLVL (ETA-14/0354) for type S with member thickness $t \geq 7 \cdot d$ and for type Q independent of the member thickness.

¹⁷ The spacings and distances given in this paragraph are only valid for "Jamo plus" screws if the screws are inserted only until the end of the smooth shaft. The spacings and distances are not valid for the underhead thread of the "Jamo plus" screws.

Würth self-tapping screws	Annex A.2
Characteristic values of the load-carrying capacities	

English translation prepared by DIBt

For Douglas fir members minimum spacing and distances parallel to the grain shall be increased by 50 %.

Minimum distances from the unloaded edge perpendicular to the grain may be reduced to $3 \cdot d$ also for timber thickness $t < 5 \cdot d$, if the spacing parallel to the grain and the end distance is at least $25 \cdot d$.

For Würth screws in non-pre-drilled softwood members except "ASSY plus", "ASSY plus VG" and "Jamo plus" the minimum member thickness defined in EN 1995-1-1, clause 8.3.1.2 as for nails in non-pre-drilled holes is valid. Equation (8.18) in EN 1995-1-1 may be applied for softwood members made of pine or for the fixing of boards, battens or wind braces, if the member is fixed with at least two screws. Otherwise EN 1995-1-1, clause 8.3.1.2 (7) applies.

If the spacing parallel to the grain and the end distance is at least $25 \cdot d$ or if the timber in the connection area is reinforced according to Annex 8, the minimum thickness for predrilled structural members or for "ASSY plus" and "ASSY plus VG" screws in non-pre-drilled softwood members may be reduced to $t = 24$ mm for screws with outer thread diameter $d < 8$ mm, to $t = 30$ mm for screws with outer thread diameter $d = 8$ mm, to $t = 40$ mm for screws with outer thread diameter $d = 10$ mm, to $t = 80$ mm for screws with outer thread diameter $d = 12$ mm and to $t = 100$ mm for screws with outer thread diameter $d = 14$ mm.

These minimum member thicknesses are not valid for wood-based panels and LVL with cross veneers.

A.2.4.3 Minimum member dimensions and minimum spacings for laterally loaded screws - Tables

A.2.4.3.1 Terms / Symbols

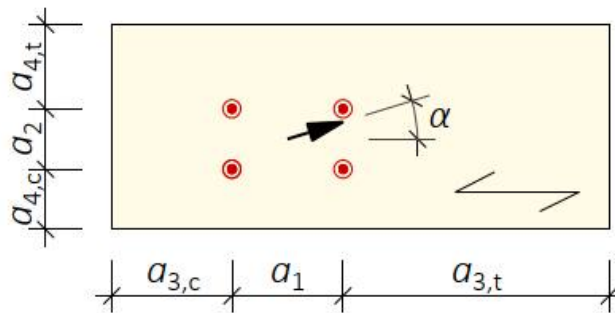

Figure A.2.1: Minimum spacings for laterally loaded screws

- a_1 Minimum spacing between two fasteners parallel to the grain
- a_2 Minimum spacing between two fasteners perpendicular to the grain
- $a_{3,c}$ Minimum spacing between an unloaded edge and a fastener parallel to the grain
- $a_{3,t}$ Minimum spacing between a loaded edge and a fastener parallel to the grain
- $a_{4,c}$ Minimum spacing between an unloaded edge and a fastener perpendicular to the grain
- $a_{4,t}$ Minimum spacing between a loaded edge and a fastener perpendicular to the grain
- α Angle between the load direction and the grain direction

Würth self-tapping screws	Annex A.2
Characteristic values of the load-carrying capacities	

English translation prepared by DIBt

A.2.4.3.2 Tables

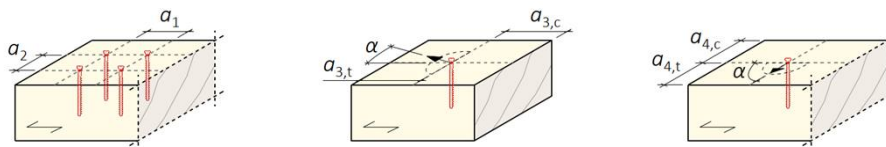

Figure A.2.2: Spacings and angles in solid timber

Table A.2.7 Minimum spacings and minimum member thicknesses for screws loaded perpendicular to the screw axis in **solid timber, glued solid timber, or glued laminated timber** with $\rho_k \leq 420 \text{ kg/m}^3$

	ASSY® plus: non-pre-drilled ASSY®: pre-drilled					ASSY®: non-pre-drilled				
a_1	$k_a \cdot (4 + \cos \alpha) \cdot d^a$					$k_a \cdot (5 + 7 \cdot \cos \alpha) \cdot d^b$				
a_2	$k_a \cdot (3 + \sin \alpha) \cdot d^a$					$k_a \cdot 5 \cdot d^a$				
$a_{3,t}$	$(7 + 5 \cdot \cos \alpha) \cdot d$					$k_a \cdot (10 + 5 \cdot \cos \alpha) \cdot d^c$				
$a_{3,c}$	$7 \cdot d$					$k_a \cdot 10 \cdot d^c$				
$a_{4,t}$	$(3 + 4 \cdot \sin \alpha) \cdot d$					$(5 + 5 \cdot \sin \alpha) \cdot d^d$				
$a_{4,c}$	$3 \cdot d$					$5 \cdot d^d$				
Minimum member thicknesses t_{min} for different outer thread diameters d										
d	6	8	10	12	14	6	8	10	12	14
t_{min}	24	30	40	80	100					
Wood species less sensitive to splitting, as specified in EN 1995-1-1, clause 8.3.1.2 (7), valid for Scots pine (<i>Pinus sylvestris</i>)^{e) f)}										
t_{min} ($\rho_k = 350 \text{ kg/m}^3$)						42	65	88	110	133
t_{min} ($\rho_k = 420 \text{ kg/m}^3$)						50	78	105	132	160
Wood species particularly sensitive to splitting, as specified in EN 1995-1-1, clause 8.3.1.2 (7), valid for all softwood species except Scots pine^{e) f)}										
t_{min} ($\rho_k = 350 \text{ kg/m}^3$)						84	130	175	221	266
t_{min} ($\rho_k = 420 \text{ kg/m}^3$)						101	155	210	265	320
Table values in mm.										
a) $k_a = 1.0$ for timber-timber connections; $k_a = 0.85$ for wood-based panel-timber connections (see Section A.1.2); $k_a = 0.7$ for steel-timber connections.										
b) $k_a = 1.0$ for timber-timber connections (Douglas fir: $k_a = 1.5$); $k_a = 0.85$ for wood-based panel-timber connections (see Section A.1.2; Douglas fir: $k_a = 1.275$); $k_a = 0.7$ for steel-timber connections (Douglas fir: $k_a = 1.05$).										
c) Generally: $k_a = 1.0$; for Douglas fir, $k_a = 1.5$.										
d) If an increased value of $10 \cdot d$ is used for the spacings $a_{4,t}$ and $a_{4,c}$, the minimum timber thicknesses t_{min} for Scots pine may also be applied to wood species particularly sensitive to splitting.										
e) For other characteristic densities, see EN 1995-1-1.										
f) The minimum timber thicknesses for Scots pine may also be used for the fastening of: 1. Formwork, rafters and counter-battens ($n \geq 2$ per connection) 2. Wind bracing straps ($n \geq 2$ per connection) 3. Cross-members on frame members ($n \geq 2$ per connection)										
Reference standard: EN 1995-1-1 (spacings, and t_{min} based on ρ_k).										

Würth self-tapping screws	Annex A.2
Characteristic values of the load-carrying capacities	

English translation prepared by DIBt

Table A.2.8 Minimum spacings and minimum member thicknesses for screws loaded perpendicular to the screw axis in **solid timber, glued solid timber, or glued laminated timber** with $\rho_k > 420 \text{ kg/m}^3$

	ASSY® plus: non-pre-drilled ASSY®: pre-drilled, (for $\rho_k > 500 \text{ kg/m}^3$: always pre-drilled!)					ASSY®: non-pre-drilled $420 \text{ kg/m}^3 < \rho_k \leq 500 \text{ kg/m}^3$				
a_1	$k_a \cdot (4 + \cos \alpha) \cdot d^a)$					$k_a \cdot (7 + 8 \cos \alpha) \cdot d^b)$				
a_2	$k_a \cdot (3 + \sin \alpha) \cdot d^a)$					$k_a \cdot 7 \cdot d^a)$				
$a_{3,t}$	$(7 + 5 \cos \alpha) \cdot d$					$k_a \cdot (15 + 5 \cos \alpha) \cdot d^c)$				
$a_{3,c}$	$7 \cdot d$					$k_a \cdot 15 \cdot d^c)$				
$a_{4,t}$	$(3 + 4 \sin \alpha) \cdot d$					$(7 + 5 \sin \alpha) \cdot d^d)$				
$a_{4,c}$	$3 \cdot d$					$7 \cdot d^d)$				
Minimum member thicknesses t_{\min} for different outer thread diameters d										
d	6	8	10	12	14	6	8	10	12	14
t_{\min}	24	30	40	80	100					
Wood species less sensitive to splitting, as specified in EN 1995-1-1, clause 8.3.1.2 (7), valid for Scots pine (<i>Pinus sylvestris</i>)^{e) f)}										
t_{\min} ($\rho_k = 425 \text{ kg/m}^3$)						51	79	106	134	162
t_{\min} ($\rho_k = 500 \text{ kg/m}^3$)						60	93	125	158	190
Wood species particularly sensitive to splitting, as specified in EN 1995-1-1, clause 8.3.1.2 (7), valid for all softwood species except Scots pine^{e) f)}										
t_{\min} ($\rho_k = 425 \text{ kg/m}^3$)						102	157	212	268	323
t_{\min} ($\rho_k = 500 \text{ kg/m}^3$)						120	185	250	315	380
Table values in mm.										
a) $k_a = 1.0$ for timber-timber connections; $k_a = 0.85$ for wood-based panel-timber connections (see Section A.1.2); $k_a = 0.7$ for steel-timber connections.										
b) $k_a = 1.0$ for timber-timber connections (Douglas fir: $k_a = 1.5$); $k_a = 0.85$ for wood-based panel-timber connections (see Section A.1.2; Douglas fir: $k_a = 1.275$); $k_a = 0.7$ for steel-timber connections (Douglas fir: $k_a = 1.05$).										
c) Generally: $k_a = 1.0$; for Douglas fir, $k_a = 1.5$.										
d) If an increased value of $14 \cdot d$ is used for the spacings $a_{4,t}$ and $a_{4,c}$, the minimum timber thicknesses t_{\min} for Scots pine may also be applied to wood species particularly sensitive to splitting.										
e) For other characteristic densities, see EN 1995-1-1.										
f) The minimum timber thicknesses for Scots pine may also be used for the fastening of: 1. Formwork, rafters and counter-battens ($n \geq 2$ per connection) 2. Wind bracing straps ($n \geq 2$ per connection) 3. Cross-members on frame members ($n \geq 2$ per connection)										
Reference standard: EN 1995-1-1 (spacings, and t_{\min} based on ρ_k).										

Würth self-tapping screws	Annex A.2
Characteristic values of the load-carrying capacities	

English translation prepared by DIBt

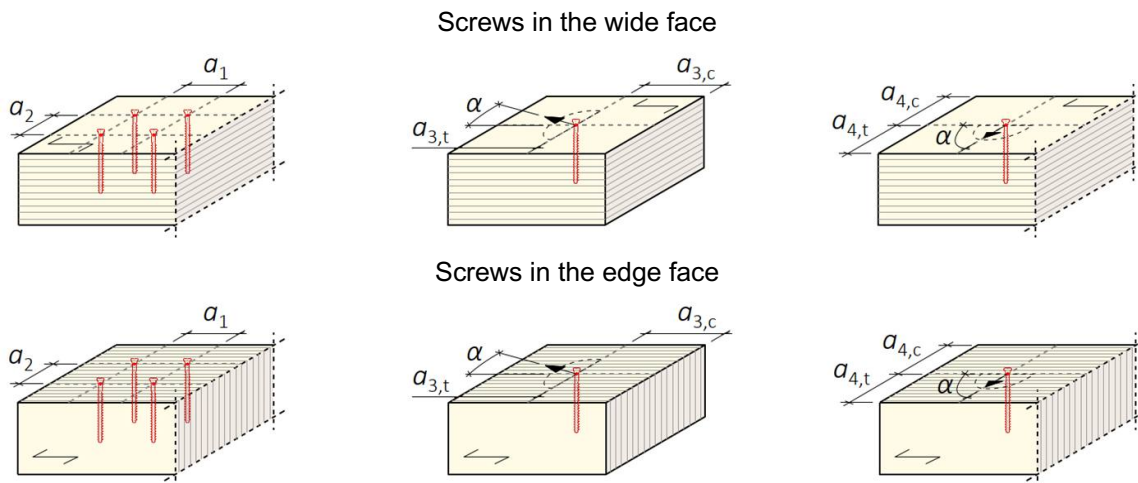

Figure A.2.3: Spacings and angles in softwood laminated veneer lumber (LVL)

Table A.2.9 Minimum spacings and minimum member thicknesses for screws loaded perpendicular to the screw axis in members made of **softwood laminated veneer lumber (LVL)**, according to EN 13986 and EN 14374

	ASSY® plus: non-pre-drilled, ASSY®: pre-drilled	ASSY®: non-pre-drilled
a_1	$k_a \cdot (4 + \cos \alpha) \cdot d^a$	$k_a \cdot (7 + 8 \cos \alpha) \cdot d^a$
a_2	$k_a \cdot (3 + \sin \alpha) \cdot d^a$	$k_a \cdot 7 \cdot d^a$
$a_{3,t}$	$(7 + 5 \cos \alpha) \cdot d$	$(15 + 5 \cos \alpha) \cdot d$
$a_{3,c}$	$7 \cdot d$	$15 \cdot d$
$a_{4,t}$	$(3 + 4 \sin \alpha) \cdot d$	$(7 + 5 \sin \alpha) \cdot d$
$a_{4,c}$	$3 \cdot d$	$7 \cdot d$

Minimum member thicknesses t_{min} for different outer thread diameters d

d	6 ^{b)}	8	10	12	14	6 ^{b)}	8	10	12	14
t_{min}	24	30	40	80	100	24	30	40	80	100

Table values in mm.

- a) $k_a = 1.0$ for timber-timber connections;
 $k_a = 0.85$ for wood-based panel-timber connections (see Section A.1.2);
 $k_a = 0.7$ for steel-timber connections.

- b) Minimum outer thread diameter for screws in the edge faces of laminated veneer lumber with cross layers (LVL-C)

Members with characteristic densities $\rho_k > 500 \text{ kg/m}^3$ shall be pre-drilled before screw insertion.

Reference standard: EN 1995-1-1 (spacings).

Würth self-tapping screws	Annex A.2
Characteristic values of the load-carrying capacities	

English translation prepared by DIBt

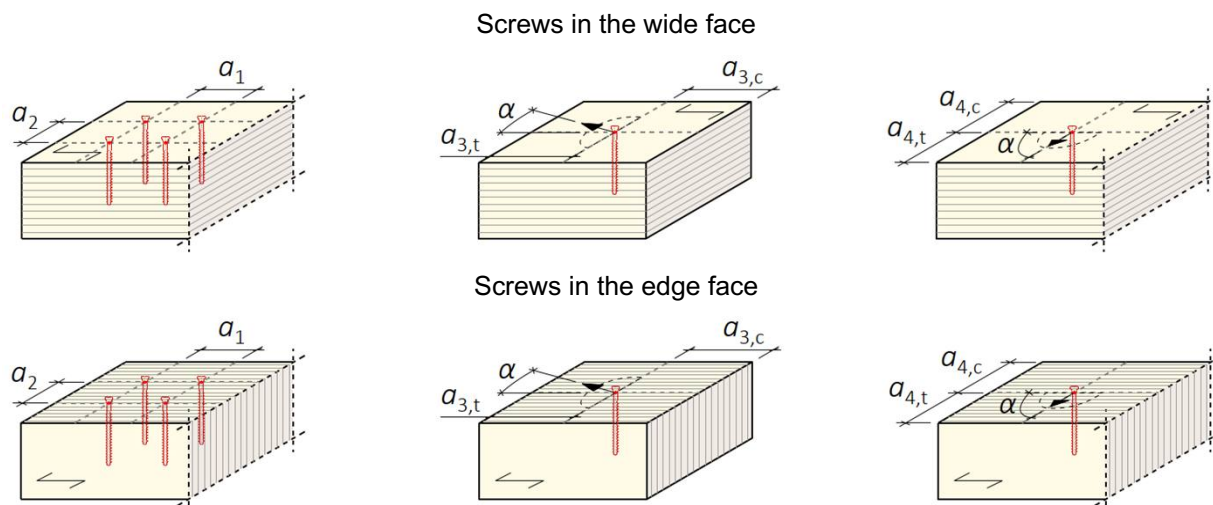

Figure A.2.4: Spacings and angles in beech laminated veneer lumber (LVL)

Table A.2.10 Minimum spacings and minimum member thicknesses for screws loaded perpendicular to the screw axis in **glued laminated timber (GL)** made of **beech laminated veneer lumber**, according to **ETA-14/0354**

	ASSY® plus: pre-drilled ASSY®: pre-drilled					ASSY® plus: non-pre-drilled ASSY®: non-pre-drilled			
a_1	$k_a \cdot (4 + \cos \alpha) \cdot d^a$					$k_a \cdot (7 + 8 \cos \alpha) \cdot d^a$			
a_2	$k_a \cdot (3 + \sin \alpha) \cdot d^a$					$k_a \cdot 7 \cdot d^a$			
$a_{3,t}$	$(7 + 5 \cos \alpha) \cdot d$					$(15 + 5 \cos \alpha) \cdot d$			
$a_{3,c}$	$7 \cdot d$					$15 \cdot d$			
$a_{4,t}$	$(3 + 4 \sin \alpha) \cdot d$					$(7 + 5 \sin \alpha) \cdot d$			
$a_{4,c}$	$3 \cdot d$					$7 \cdot d$			
Minimum member thicknesses t_{\min} for different outer thread diameters d									
d	6	8	10	12	14	6	8	10	12
t_{\min}	24	30	40	80	100	42 ^{b)}	56 ^{b)}	70 ^{b)}	84 ^{b)}
Table values in mm.									
a) $k_a = 1.0$ for timber-timber connections; $k_a = 0.85$ for wood-based panel-timber connections (see Section A.1.2); $k_a = 0.7$ for steel-sheet-timber connections.									
b) Minimum thickness $t \geq 7 \cdot d$ valid for $5 \leq d \leq 12$, Type S; for Type Q, no minimum thickness is required. Members with characteristic densities $\rho_k > 500 \text{ kg/m}^3$ shall be pre-drilled before screw insertion.									
Reference standard: EN 1995-1-1									

The screw-in depth without pre-drilling in beech LVL according to ETA-14/0354 is limited. See Table A.1.2 for details.

Würth self-tapping screws	Annex A.2
Characteristic values of the load-carrying capacities	

English translation prepared by DIBt

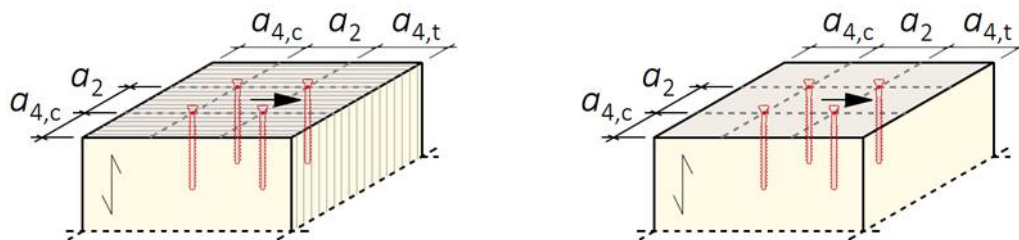

Figure A.2.5: Definition of edge and axial spacings for screws arranged parallel to the grain in end grain (angle between screw axis and grain direction equals 0°). Left: laminated veneer lumber; right: solid timber.

Table A.2.11 Minimum spacings for screws loaded perpendicular to the screw axis in end-grain surfaces with an angle between screw axis and grain direction equal to 0°, in members made of **solid timber, glued solid timber, laminated veneer lumber, or glued laminated timber made of softwood**

	ASSY® plus: non-pre-drilled, ASSY®: pre-drilled		ASSY®: non-pre-drilled		
	$\rho_k \leq 500 \text{ kg/m}^3$		$\rho_k \leq 420 \text{ kg/m}^3$	$420 \text{ kg/m}^3 < \rho_k \leq 500 \text{ kg/m}^3$	
a_2	4 · d		5 · d	7 · d	
$a_{4,t}$	7 · d		10 · d	12 · d	
$a_{4,c}$	3 · d		5 · d	7 · d	
Minimum embedment depths l_{ef} for various nominal thread diameters d					
d	6	8	10	12	14
t_h	60	80	100	120	140

Table values in mm.
Reference standard: EN 1995-1-1 (Table 8.2)

Würth self-tapping screws	Annex A.2
Characteristic values of the load-carrying capacities	

English translation prepared by DIBt

A.2.4.4 Only axially loaded screws

For "ASSY plus", "ASSY plus VG" and "Jamo plus"¹³ screws loaded only axially, the following minimum spacings, end and edge distances may be used alternatively to paragraph A.2.4.2 for solid timber, glued laminated timber and similar glued products:

Spacing a_1 in a plane parallel to grain:	$a_1 = 5 \cdot d$
Spacing a_2 perpendicular to a plane parallel to grain:	$a_2 = 2.5 \cdot d$
End distance $a_{1,CG}$ of the centre of gravity of the threaded part in the timber member:	$a_{3,CG} = 5 \cdot d$
Edge distance $a_{2,CG}$ of the centre of gravity of the threaded part in the timber member:	$a_{4,CG} = 3 \cdot d$
Product of spacing a_1 and a_2 :	$a_1 \cdot a_2 = 25 \cdot d^2$

For screws in non-pre-drilled holes a minimum timber thickness of $10 \cdot d$ and a minimum width of $8 \cdot d$ or 60 mm, whichever is the greater, are required.

For "ASSY plus" and "ASSY plus VG" and "Jamo plus" screws only loaded axially, the following minimum spacings, end and edge distances apply for laminated veneer lumber (LVL) made from softwood:

Spacing a_1 in a plane parallel to grain:	$a_1 = 5 \cdot d$
Spacing a_2 perpendicular to a plane parallel to grain:	$a_2 = 2.5 \cdot d$
End distance $a_{1,CG}$ of the centre of gravity of the threaded part in the timber member:	$a_{3,CG} = 5 \cdot d$
Edge distance $a_{2,CG}$ of the centre of gravity of the threaded part in the timber member:	$a_{4,CG} = 3 \cdot d$
Product of spacing a_1 and a_2 :	$a_1 \cdot a_2 = 25 \cdot d^2$

For screws in non-pre-drilled holes a minimum LVL (softwood) thickness of $6 \cdot d$ and a minimum width of $8 \cdot d$ or 60 mm, whichever is the greater, are required.

For a crossed screw couple in solid timber, glued laminated timber and similar glued products or in laminated veneer lumber the minimum spacing between the crossing screws is $1.5 \cdot d$. Appropriate means have to ensure that the crossed screws threads do not touch each other when being inserted in the timber member.

Regardless of the angle between the screw axis and the top layer, the minimum edge distance perpendicular to the grain of the plywood flanges of I-beams may be reduced to 2 times the screw diameter ($2 \cdot d$) for screw diameters of $d \leq 8$ mm and member thicknesses of $t \geq 30$ mm, provided that the screw spacing parallel to the grain is at least 10 times the screw diameter ($10 \cdot d$) and the distance to the end grain of the wood is maintained. The screws shall be centrally located in the flanges of the I-beams.

Würth self-tapping screws	Annex A.2
Characteristic values of the load-carrying capacities	

English translation prepared by DIBt

A.2.4.5 Axially loaded screws – Symbols

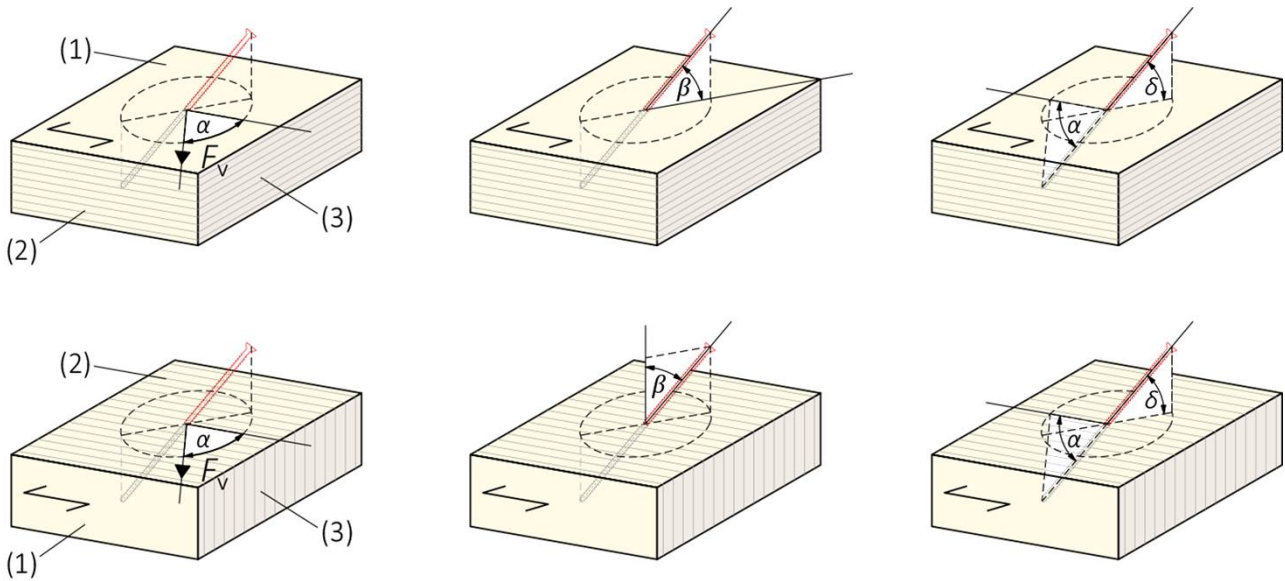

Figure A.2.6: Angle of screws and members

- (1) Wide surface
- (2) Narrow surface
- (3) End grain surface
- F_v Laterally acting force
- α Angle between force direction and grain direction / screw axis and grain direction
- β Angle between screw axis and top surface
- δ Angle between screw axis and shear plane

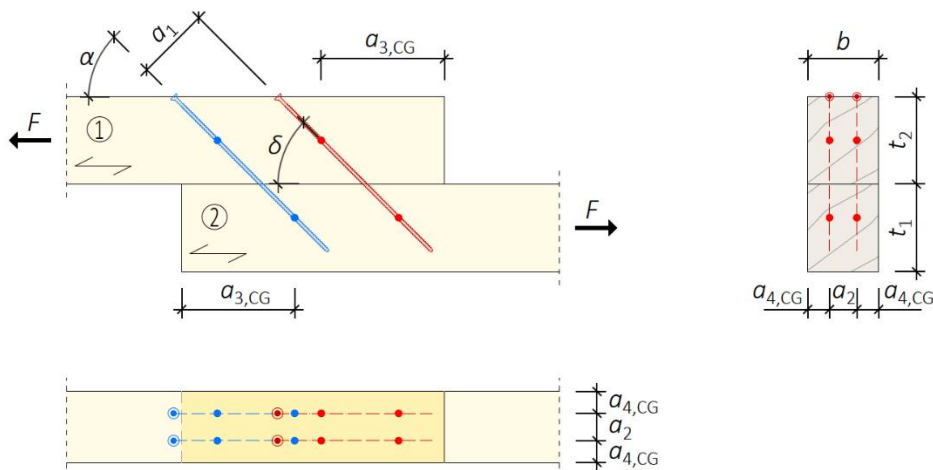

Figure A.2.7: Minimum distances and angle specifications for screws inclined to the grain direction, $\delta = \alpha$

Würth self-tapping screws	Annex A.2
Characteristic values of the load-carrying capacities	

English translation prepared by DIBt

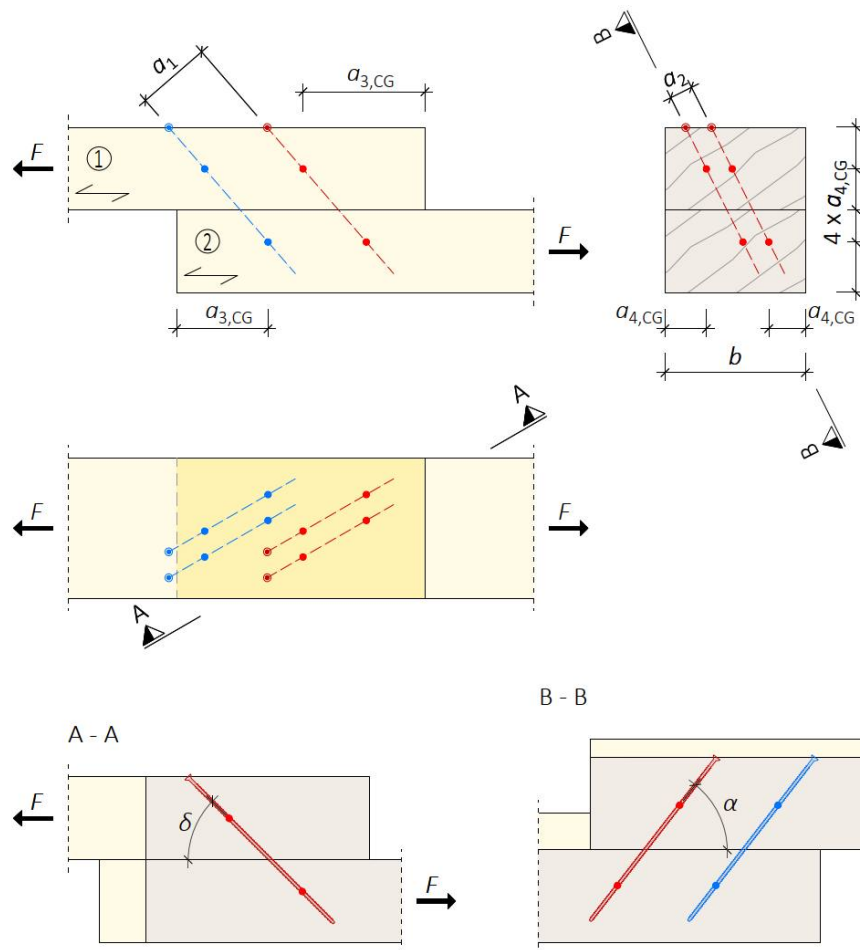

Figure A.2.8: Minimum distances and angle specifications for screws inclined in two directions, $\delta \neq \alpha$

- a_x Minimum distance between two screws in a screw cross
- b Member width
- t_1 Thickness of member 1
- t_2 Thickness of member 2
- F Acting force
- 1 Member 1 (in a connection)
- 2 Member 2 (in a connection)

Würth self-tapping screws	Annex A.2
Characteristic values of the load-carrying capacities	

English translation prepared by DIBt

A.2.4.6 Axially loaded screws – Tables

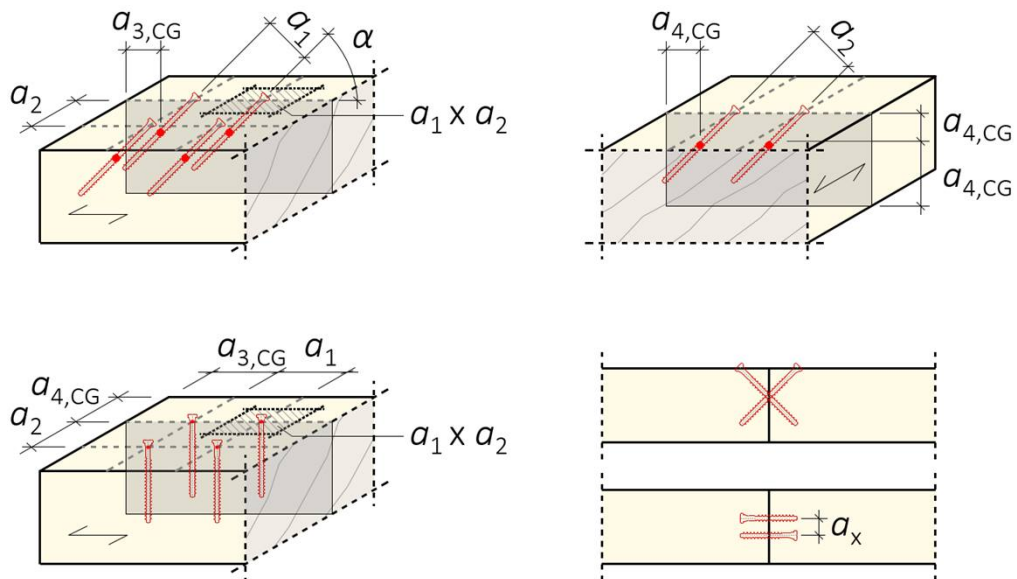

Figure A.2.9: Distances and angles in solid wood

Würth self-tapping screws	Annex A.2
Characteristic values of the load-carrying capacities	

English translation prepared by DIBt

Table A.2.12 Minimum distances and minimum member dimensions for axially loaded screws in **solid wood** or **glued laminated timber (glulam)** with $\rho_k \leq 420 \text{ kg/m}^3$

	ASSY® plus: non-pre-drilled					ASSY® plus: non-pre-drilled ASSY®: pre-drilled					ASSY®: non-pre-drilled				
a_1	$5 \cdot d$					$(4 + \cos \alpha) \cdot d$					$k_a (5 + 7 \cos \alpha) \cdot d^a$				
a_2	$2.5 \cdot d$					$(3 + \sin \alpha) \cdot d$					$5 \cdot d$				
$a_{3,CG}$	$5 \cdot d$					$7 \cdot d$					$k_a \cdot 10 \cdot d^a$				
$a_{4,CG}$	$3 \cdot d$					$3 \cdot d$					$\begin{matrix} 5 \cdot d \\ 10 \cdot d^b \end{matrix}$				
$a_1 \times a_2$	$25 \cdot d^2$					keine Vorgaben					keine Vorgaben				
a_x	$1.5 \cdot d$					$1.5 \cdot d$					$1.5 \cdot d$				
Minimum member dimensions for different external thread diameters d															
d	6	8	10	12	14	6	8	10	12	14	6	8	10	12	14
t_{min}	60	80	100	120	140	24	30	40	80	100					
b_{min}	60	64	80	96	112										
Wood species less sensitive to splitting, as specified in EN 1995-1-1, clause 8.3.1.2 (7) valid for Scots Pine (<i>Pinus sylvestris</i>)^{c)}															
$t_{min} (\rho_k = 350 \text{ kg/m}^3)$						42	65	88	110	133					
$t_{min} (\rho_k = 420 \text{ kg/m}^3)$						50	78	105	132	160					
Wood species particularly sensitive to splitting, as specified in EN 1995-1-1, clause 8.3.1.2 (7) valid for all wood species^{c)} except Scots Pine.															
$t_{min} (\rho_k = 350 \text{ kg/m}^3)$						84	130	175	221	266					
$t_{min} (\rho_k = 420 \text{ kg/m}^3)$						101	155	210	265	320					
Table values in mm.															
The values also apply to connections between solid wood, glued laminated timber (glulam) or with wood-based panels as per Section A.1.2 or with steel.															
a) General: $k_a = 1.0$; for Douglas Fir, $k_a = 1.5$															
b) Minimum value for members made of wood species particularly sensitive to splitting, where the rules for minimum wood thicknesses for wood species less sensitive to splitting (such as Scots Pine) may be applied.															
c) For other characteristic densities, refer to EN 1995-1-1															
Regulations: EN 1995-1-1 (Distances in columns 2 and 3, minimum thickness t_{min} related to ρ_k)															

Würth self-tapping screws	Annex A.2
Characteristic values of the load-carrying capacities	

English translation prepared by DIBt

Table A.2.13 Minimum distances and minimum member dimensions for axially loaded screws in **solid wood** and **glued laminated timber (glulam)** with $\rho_k > 420 \text{ kg/m}^3$

	ASSY® plus: non-pre-drilled					ASSY® plus: non-pre-drilled ASSY®: pre-drilled					ASSY®: non-pre-drilled				
a_1	$5 \cdot d$					$(4 + \cos \alpha) \cdot d$					$k_a \cdot (5 + 7 \cos \alpha) \cdot d$ ^{a)}				
a_2	$2.5 \cdot d$					$(3 + \sin \alpha) \cdot d$					$5 \cdot d$				
$a_{3,CG}$	$5 \cdot d$					$7 \cdot d$					$k_a \cdot 10 \cdot d$ ^{a)}				
$a_{4,CG}$	$3 \cdot d$					$3 \cdot d$					$5 \cdot d$ $10 \cdot d$ ^{b)}				
$a_1 \times a_2$	$25 \cdot d^2$					No requirements					No requirements				
a_x	$1.5 \cdot d$					$1.5 \cdot d$					$1.5 \cdot d$				
Minimum member dimensions for different external thread diameters d															
d	6	8	10	12	14	6	8	10	12	14	6	8	10	12	14
t_{min}	60	80	100	120	140	24	30	40	80	100					
b_{min}	60	64	80	96	112										
Wood species less sensitive to splitting, as specified in EN 1995-1-1, clause 8.3.1.2 (7) valid for Scots Pine (<i>Pinus sylvestris</i>)^{c)}															
t_{min} ($\rho_k = 350 \text{ kg/m}^3$)											42	65	88	110	133
t_{min} ($\rho_k = 420 \text{ kg/m}^3$)											50	78	105	132	160
Wood species particularly sensitive to splitting, as specified in EN 1995-1-1, clause 8.3.1.2 (7) valid for all wood species^{c)} except Scots Pine.															
t_{min} ($\rho_k = 350 \text{ kg/m}^3$)											84	130	175	221	266
t_{min} ($\rho_k = 420 \text{ kg/m}^3$)											101	155	210	265	320
Table values in mm.															
The values also apply to connections between solid wood, glued laminated timber (glulam), or laminated veneer lumber (LVL) with wood-based panels as per Section A.1.2, or with steel plates.															
a) General: $k_a = 1.0$; for Douglas Fir, $k_a = 1.5$															
b) Minimum value for members made of wood species particularly sensitive to splitting, where the rules for minimum wood thicknesses for wood species less sensitive to splitting (such as Scots Pine) may be applied.															
c) For other characteristic densities, refer to EN 1995-1-1															
Regulations: EN 1995-1-1 (Distances in columns 2 and 3, minimum thickness t_{min} related to ρ_k)															

Würth self-tapping screws	Annex A.2
Characteristic values of the load-carrying capacities	

English translation prepared by DIBt

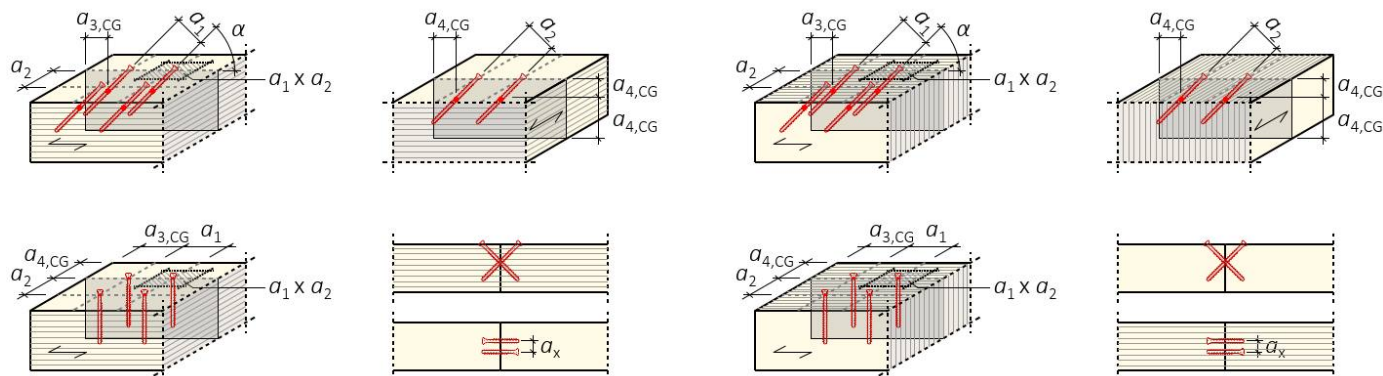

Figure A.2.10: Distances and angles in laminated veneer lumber (LVL) made of softwood when installed in the wide surface (left, $\beta = 90^\circ$) and in the narrow surface (right, $\beta = 0^\circ$)

Table A.2.14 Minimum distances and minimum member dimensions for axially loaded screws in **laminated veneer lumber (LVL)** made of **softwood** as specified in EN 13986 and EN 14374

	ASSY® plus: non-pre-drilled	ASSY® plus: non-pre-drilled ASSY®: pre-drilled	ASSY®: non-pre-drilled
a_1	$5 \cdot d$	$(4 + \cos \alpha) \cdot d$	$(5 + 7 \cos \alpha) \cdot d$
a_2	$2.5 \cdot d$	$(3 + \sin \alpha) \cdot d$	$5 \cdot d$
$a_{3,CG}$	$5 \cdot d$	$7 \cdot d$	$10 \cdot d$
$a_{4,CG}$	$3 \cdot d$	$3 \cdot d$	$5 \cdot d$
$a_1 \times a_2$	$25 \cdot d^2$	No requirements	No requirements
a_x	$1.5 \cdot d$	$1.5 \cdot d$	$1.5 \cdot d$

Minimum member dimensions for different external thread diameters d

d	6	8	10	12	14	6	8	10	12	14	6	8	10	12	14
t_{min}	36	48	60	72	84	24	30	40	80	100	72	96	120	144	168
b_{min}	60	64	80	96	112										

Table values in mm.

The values also apply to connections between laminated veneer lumber (LVL) and wood-based panels according to Section A.1.2, or with steel plates.

Members with characteristic densities $\rho_k > 500 \text{ kg/m}^3$ shall be pre-drilled before screwing.

Regulation: EN 1995-1-1 (Distances in columns 2 and 3)

Würth self-tapping screws	Annex A.2
Characteristic values of the load-carrying capacities	

English translation prepared by DIBt

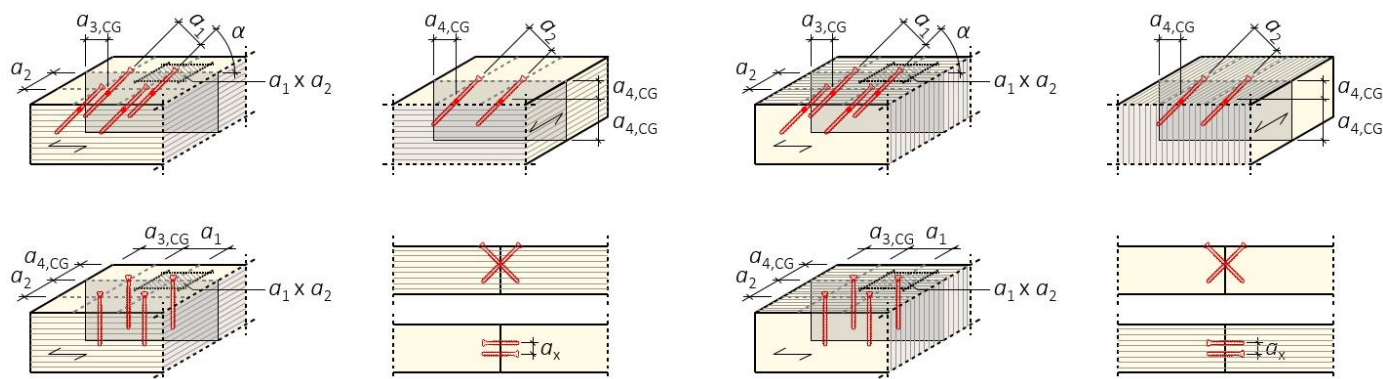

Figure A.2.11: Distances and angles in laminated veneer lumber (LVL) made of beech when installed in the top surface (left, $\beta = 90^\circ$) and in the narrow surface (right, $\beta = 0^\circ$)

Table A.2.15 Minimum distances and minimum member dimensions for axially loaded screws in glued laminated timber (glulam) made from beech laminated veneer lumber (LVL) according to ETA-14/0354

	ASSY® plus: non-pre-drilled	ASSY® plus: non-pre-drilled ASSY®: pre-drilled	ASSY®: non-pre-drilled
a_1	$5 \cdot d$	$(4 + \cos \alpha) \cdot d$	$(7 + 8 \cdot \cos \alpha) \cdot d$
a_2	$2.5 \cdot d$	$(3 + \sin \alpha) \cdot d$	$7 \cdot d$
$a_{3,CG}$	$5 \cdot d$	$7 \cdot d$	$15 \cdot d$
$a_{4,CG}$	$3 \cdot d$	$3 \cdot d$	$7 \cdot d$
$a_1 \times a_2$	$25 \cdot d^2$	No requirements	No requirements
a_x	$1.5 \cdot d$	$1.5 \cdot d$	$1.5 \cdot d$

Minimum member dimensions for different external thread diameters d

d	6	8	10	12	14	6	8	10	12	6	8	10	12
t_{min}	60	80	100	120	140	42 ^{a)}	56 ^{a)}	70 ^{a)}	84 ^{a)}	42 ^{a)}	56 ^{a)}	70 ^{a)}	84 ^{a)}
b_{min}	60	64	80	96	112								

Table values in mm.

The values also apply to connections between glued laminated veneer lumber (GLVL) made from beech and wood-based materials as per Section A.1.2, or with steel plates.

^{a)} Minimum thickness $t \geq 7d$ valid for $5 \text{ mm} \leq d \leq 12 \text{ mm}$, Type S; no minimum thickness is required for Type Q.

Regulation: EN 1995-1-1 (Distances in columns 2 and 3)

The screw-in depth without pre-drilling in glued laminated veneer lumber (GLVL) made from beech according to ETA-14/0354 is limited. See Table A.1.2 for details.

Würth self-tapping screws	Annex A.2
Characteristic values of the load-carrying capacities	

English translation prepared by DIBt

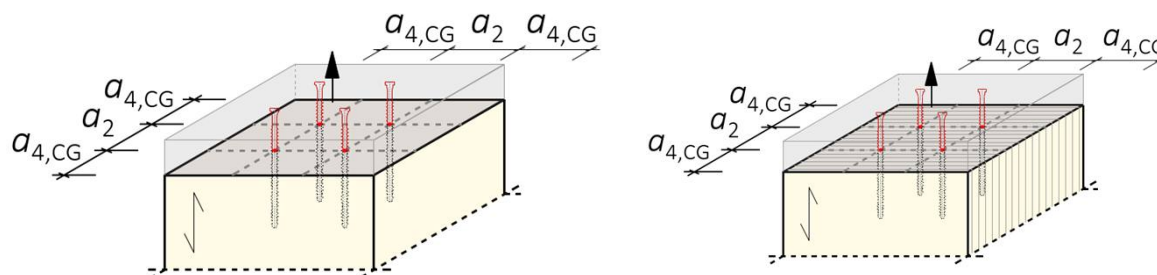

Figure A.2.12: Definition of edge and axis distances for screws with parallel grain orientation in end grain (angle between screw axis and grain direction equals 0°) of solid wood products (left) and laminated veneer lumber (right)

Table A.2.16 Minimum distances for axially loaded screws with parallel grain orientation in end grain (angle between screw axis and grain direction equals 0°) for members made of solid wood, glued laminated timber (glulam), laminated veneer lumber (LVL), or laminated wood (LW)

	ASSY® plus: non-pre-drilled ^{a)} ASSY®: pre-drilled		ASSY®: non-pre-drilled		
			$\rho_k \leq 420 \text{ kg/m}^3$	$420 \text{ kg/m}^3 < \rho_k \leq 500 \text{ kg/m}^3$	
a_2	$3 \cdot d$		$5 \cdot d$	$7 \cdot d$	
$a_{4,CG}$	$3 \cdot d$		$5 \cdot d$	$7 \cdot d$	
Minimum penetration length t_h for different external thread diameters d					
d	6	8	10	12	14
t_h	120	160	200	240	280
Table values in mm.					
The values also apply to connections between solid wood, glued laminated timber (glulam), or laminated veneer lumber (LVL) with wood-based materials according to Section A.1.2, or with steel plates.					
^{a)} Members with a characteristic density $\rho_k > 500 \text{ kg/m}^3$ shall generally be pre-drilled.					

Würth self-tapping screws	Annex A.2
Characteristic values of the load-carrying capacities	

English translation prepared by DIBt

A.2.4.7 Cross laminated timber

The requirements for the minimum distances of screws in the wide and narrow surfaces of cross-laminated timber (CLT) are given in Table A.2.17 (screws loaded perpendicular to grain) and Table A.2.18 (axially loaded screws). The definitions of the minimum distances are provided in Figure A.2.13 and Figure A.2.14. The minimum distances in the end grain faces are independent of the angle between the screw axis and the grain direction. The following conditions shall be met for the minimum distances to be applied with:

- Minimum thickness of the cross-laminated timber: $10 \cdot d$
- Minimum penetration length of screws in the narrow face of the cross-laminated timber: $10 \cdot d$

For loads perpendicular to the wide faces (see Figure A.2.13), the members made of cross-laminated timber should be reinforced with screws.

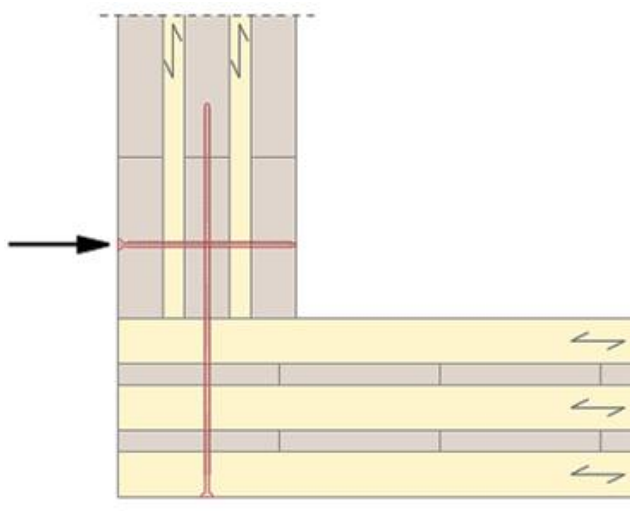

Figure A.2.13: Reinforcement of cross-laminated timber (CLT) members with screws under transverse tensile stress perpendicular to the wide faces

Würth self-tapping screws	Annex A.2
Characteristic values of the load-carrying capacities	

English translation prepared by DIBt

A.2.4.8 Minimum member dimensions and minimum distances in cross-laminated timber (CLT) – Tables

Unless otherwise stated in the European Technical Assessments for CLT, the minimum values for screw centre-to-centre and edge distances in cross-laminated timber are defined according to Tables A.2.16 and A.2.17.

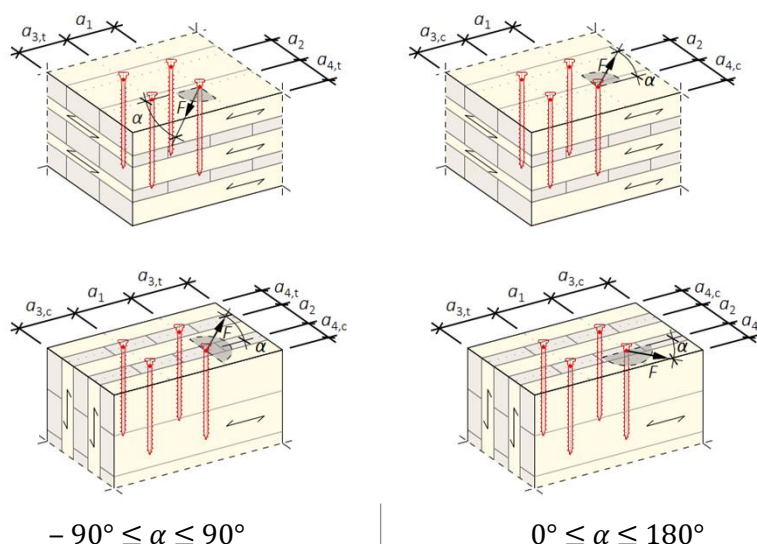

Figure A.2.14: Distances and symbols perpendicular to the screw axis for loaded screws in the wide face (top) and the narrow face (bottom) of cross-laminated timber (CLT)

Table A.2.17 Minimum distances for screwing into the wide faces or narrow faces of laterally loaded screws in **cross-laminated timber (CLT) made of softwood**

	Pre-drilled or non-pre-drilled									
	Wide face					Narrow surface				
a_1	$4 \cdot d$					$10 \cdot d$				
a_2	$2.5 \cdot d$					$4 \cdot d$				
$a_{3,t}$	$6 \cdot d$					$12 \cdot d$				
$a_{3,c}$	$6 \cdot d$					$7 \cdot d$				
$a_{4,t}$	$6 \cdot d$					$6 \cdot d$				
$a_{4,c}$	$2.5 \cdot d$					$3 \cdot d$				

Minimum member thicknesses and minimum penetration length for different external thread diameters d										
d	6	8	10	12	14	6	8	10	12	14
t_{CLT}	60	80	100	120	140	60	80	100	120	140
t_h	No specifications					60	80	100	120	140

Table values in mm.
The values also apply to connections between cross-laminated timber (CLT) and steel plates.
Screwing from the narrow face side into the top layer is only allowed if the top layer is considered as a single member ("board"), and the corresponding fastener spacing requirements are met. See also Equation 2.9. In the case of two similarly oriented outer board layers, the inner board layer is counted as its own layer.

Würth self-tapping screws	Annex A.2
Characteristic values of the load-carrying capacities	

English translation prepared by DIBt

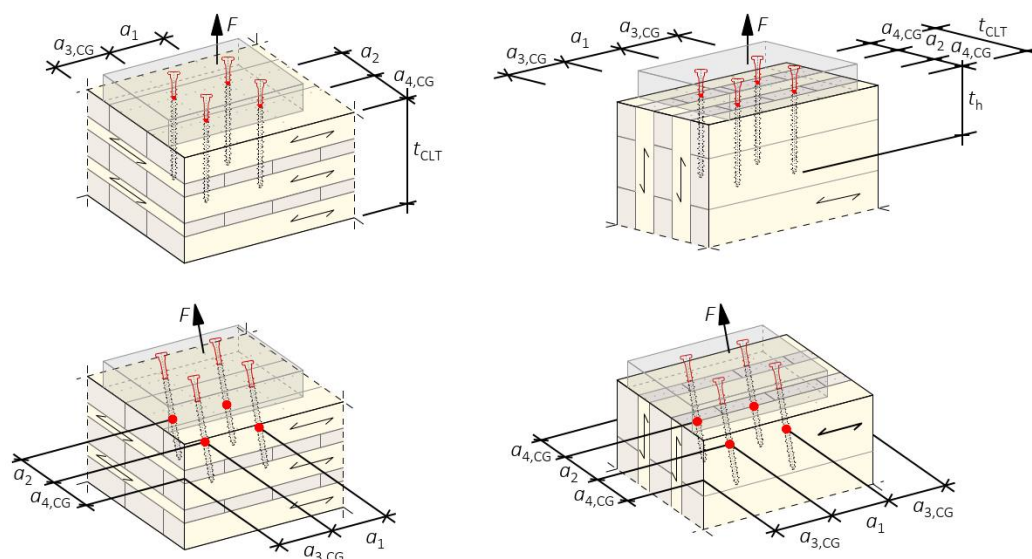

Figure A.2.15: Distances and symbols for axially loaded screws in cross-laminated timber (CLT) wide face (left) and narrow face (right)

Table A.2.18 Minimum distances for screwing into the wide faces or narrow faces of axially loaded screws in cross-laminated timber (CLT) made of softwood

		Pre-drilled or non-pre-drilled									
		Wide face					Narrow surface				
a_1		$4 \cdot d$					$10 \cdot d$				
a_2		$2.5 \cdot d$					$4 \cdot d$				
$a_{3,CG}$		$6 \cdot d$					$7 \cdot d$				
$a_{4,CG}$		$2.5 \cdot d$					$3 \cdot d$				
Minimum member thicknesses t_{CLT} and penetration length t_h for different external thread diameters d											
d	6	8	10	12	14	6	8	10	12	14	
t_{CLT}	60	80	100	120	140	60	80	100	120	140	
t_h	No specifications					60	80	100	120	140	

Table values in mm.

The values also apply to connections between cross-laminated timber (CLT) and steel plates.

Screws in the narrow face that embed only in the outermost layer (top layer) are not allowed. In the case of double edge layers (two similarly oriented edge layers), the inner edge layer is considered its own layer.

For screws with a defined position in the inner board layers of the narrow face, the distances are the same as for solid wood according to Table A.2.13. The distance to the glue joint may be reduced to $2 \cdot d$ (see Figure A.2.16).

Würth self-tapping screws	Annex A.2
Characteristic values of the load-carrying capacities	

English translation prepared by DIBt

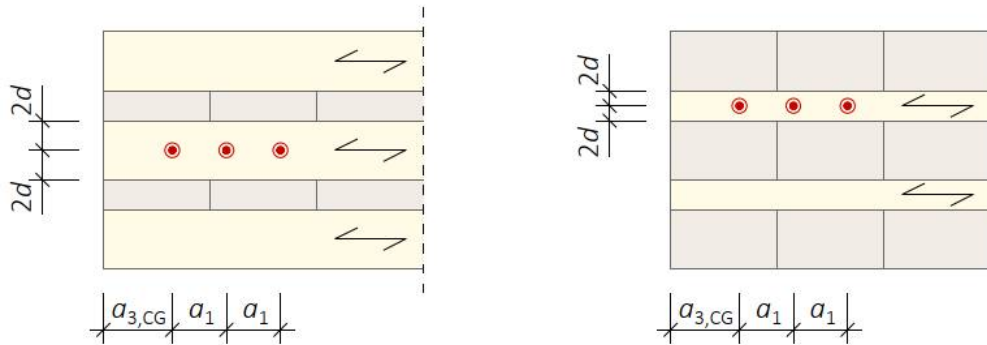

Figure A.2.16: Defined screw position in the inner board layers of the narrow face

A.2.5 Insertion moment

The ratio between the characteristic torsional strength $f_{tor,k}$ and the mean value of insertion moment $R_{tor,mean}$ fulfills the requirement for all screws.

A.2.6 Durability against corrosion

Screws and washers made from carbon steel may be uncoated. Possible surface coatings include: plain, brass-plated, nickel-plated, blued, electro-galvanized, blue passivated, yellow chromated, black chromated, zinc-nickel, passivated zinc-nickel, zinc lamella, Ruspert, fully or partially painted, hot-dip galvanized, aluminium coating, phosphated, HCP coating, Delta coating, KTL coating, or sliding coating. Surface coatings may be combined. The minimum thickness of the zinc coating on screws is 5 μm , and that of the zinc-nickel coating is 4 μm . The screw surface may exhibit varying coloration.

Würth ASSY plus VG with $d = 14 \text{ mm}$ may be hot-dip galvanized.

Steel no. 1.4006, 1.4009, 1.4021, 1.4301, 1.4401, 1.4529, 1.4571, 1.4567, 1.4578 and 1.4539 is used for screws and washers made from stainless steel.

Contact corrosion shall be avoided.

Würth self-tapping screws	Annex A.2
Characteristic values of the load-carrying capacities	

English translation prepared by DIBt

A.3 Compression reinforcement perpendicular to the grain (informative)¹⁸

A.3.1 General

Only Würth "ASSY plus VG" and "ASSY" screws with full thread shall be used for compression reinforcement perpendicular to the grain. The provisions are valid for reinforcing timber members made of solid timber, glued solid timber and glued laminated timber made of softwood.

The compression force shall evenly be distributed to the screws used as compression reinforcement.

The screws are driven into the timber member perpendicular to the contact surface under an angle between the screw axis and the grain direction of 45° to 90°. The screw heads shall be flush with the timber surface.

Compressive reinforcing screws for wood-based panels and timber members made of hardwood are not covered by this European Technical Assessment.

A.3.2 Design

For the design of reinforced contact areas, the following conditions shall be met independently of the angle between the screw axis and the grain direction.

The design resistance of a reinforced contact area is:

$$R_{90,d} = \min \left\{ \begin{array}{l} k_{c,90} \cdot B \cdot \ell_{ef,1} \cdot f_{c,90,d} + n \cdot \min \{ R_{ax,d}; \kappa_c \cdot N_{pl,d} \} \\ B \cdot \ell_{ef,2} \cdot f_{c,90,d} \end{array} \right. \quad (3.1)$$

where:

$k_{c,90}$ parameter according to EN 1995-1-1, clause 6.1.5

B bearing width [mm]

$\ell_{ef,1}$ effective contact length according to EN 1995-1-1, clause 6.1.5 [mm]

$f_{c,90,d}$ design compressive strength perpendicular to the grain [N/mm²]

n number of reinforcing screws, $n = n_0 \cdot n_{90}$

n_0 number of reinforcing screws arranged in a row parallel to the grain

n_{90} number of reinforcing screws arranged in a row perpendicular to the grain

$$R_{ax,d} = f_{ax,d} \cdot d \cdot \ell_{ef} \quad [N] \quad (3.2)$$

$f_{ax,d}$ design value of the axial withdrawal capacity of the threaded part of the screw [N/mm²]

d outer thread diameter of the screw [mm]

κ_c according to Annex 2, chapter "compressive capacity"

$N_{pl,d}$ according to Annex 2, chapter "compressive capacity" [N]

$\ell_{ef,2}$ effective contact length in the plane of the screw tips (see Figure A.3.1) [mm]

$\ell_{ef,2} = \{ \ell_{ef} + (n_0 - 1) \cdot a_1 + \min(\ell_{ef}; a_{1,C}) \}$ for end supports (see Figure A.3.1 left)

$\ell_{ef,2} = \{ 2 \cdot \ell_{ef} + (n_0 - 1) \cdot a_1 \}$ for intermediate supports (see Figure A.3.1 right)

¹⁸ The information given in this Annex is not based on an assessment according to the provisions of the EAD which is used as basis for the issuing of this ETA and is, thus, also not based on an agreement within EOTA. It is not linked to any provision of Regulation (EU) No. 2024/3110 of the European Parliament and of the Council of 27 November 2024 laying down harmonised rules for the marketing of construction products and repealing Regulation (EU) No 305/2011 and cannot be used when drawing up a declaration of performance and conformity according to this Regulation.

Würth self-tapping screws	Annex A.3
Compression reinforcement perpendicular to the grain (informative)	

English translation prepared by DIBt

- l_{ef} penetration length of the threaded part of the screw in the timber member [mm]
- a_1 spacing a_1 in a plane parallel to grain, see chapter A.2.4.4 [mm]
- $a_{3,CG}$ end distance of the centre of gravity of the threaded part in the timber member, see chapter A.2.4.4 [mm]

When screws are driven from both the top and bottom into a timber member, for example, to transfer a load, and the screws overlap by at least $10 \cdot d$, i.e., $l_{ef,top} + l_{ef,bottom} \geq h + 10 \cdot d$, the second term in Equation (3.1) may be neglected. h is the beam height, see Figure 3.3.

If screws pass through the member from the top to the bottom, for example, by cutting off the protruding screw tips flush with the top or bottom, the load-bearing capacity of the reinforced contact area is:

$$R_{90,d} = n \cdot \kappa_c \cdot N_{pl,d} \quad [N] \tag{3.3}$$

The members should be pre-drilled (drill hole diameter see Table A.1.1). For screws that are screwed in over the entire member depth h , the difference $\Delta F_{90,Ed}$ of the forces applied to the top and bottom surfaces should satisfy the following condition:

$$\Delta F_{90,Ed} \leq n \cdot f_{ax,d} \cdot d \cdot l_{ef} \quad [N] \tag{3.4}$$

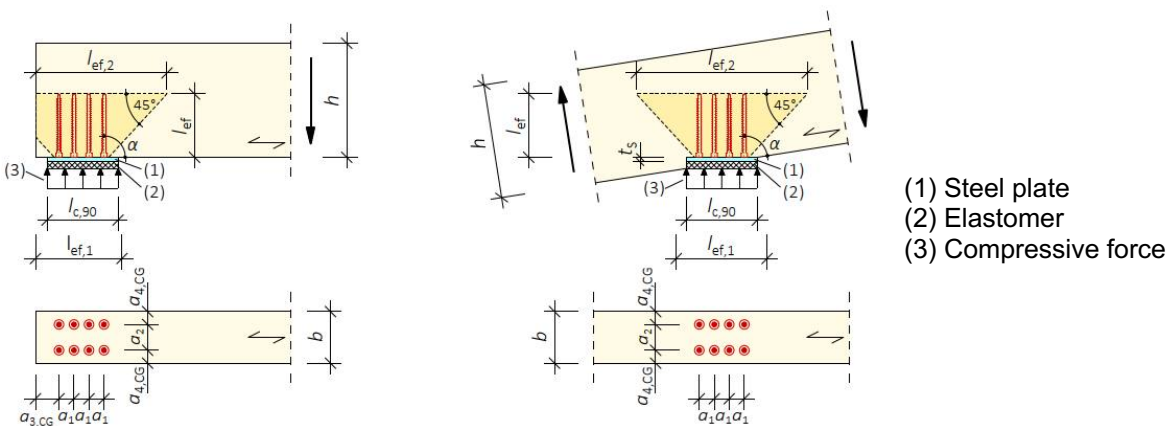

Figure A.3.1: Reinforced end support (left) and reinforced intermediate support (right)

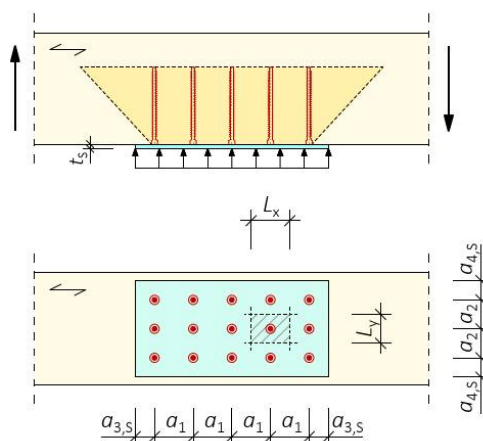

Figure A.3.2: Spacing designations on the bearing plate

Würth self-tapping screws	Annex A.3
Compression reinforcement perpendicular to the grain (informative)	

English translation prepared by DIBt

A.4 Tensile reinforcement perpendicular to grain (informative)¹⁹

A.4.1 General

Only Würth "ASSY plus VG" and "ASSY" screws with full thread shall be used for tensile reinforcement perpendicular to the grain.

The provisions regarding tensile reinforcement perpendicular to the grain are valid for the following timber members:

- solid timber of softwood or of the hardwood species beech, ash or oak,
- glued laminated timber made of softwood or of the hardwood species beech, ash or oak,
- glued solid timber made of softwood or of the hardwood species beech, ash or oak,
- laminated veneer lumber made of softwood.

For the design and construction of the tensile reinforcement of timber members perpendicular to the grain, the provisions at the place of installation shall apply. As examples connection forces at an angle to the grain and notched beam supports are given in the following.

Note: For example, in Germany the provisions of standard DIN EN 1995-1-1/NA:2013-08, NCI NA.6.8 and amendments shall be taken into account.

A minimum of two screws shall be used for tensile reinforcement perpendicular to the grain. Only one screw may be used when the minimum penetration depth of the screws below and above the potential crack is $20 \cdot d$ where d is the outer thread diameter of the screw.

A.4.2 Design

A.4.2.1 Connection forces at an angle to the grain

The axial capacity of a reinforcement of a timber member loaded by a connection force perpendicular to the grain shall fulfil the following condition:

$$\frac{[1 - 3 \cdot \alpha^2 + 2 \cdot \alpha^3] \cdot F_{90,d}}{F_{ax,Rd}} \leq 1 \tag{4.1}$$

where

- $F_{90,d}$ design value of the force component perpendicular to the grain,
- α = a/h
- a see Figure A.4.1
- h = member depth
- $F_{ax,Rd}$ = $\min \{ f_{ax,d} \cdot d \cdot l_{ef}; F_{t,Rd} \}$
- $f_{ax,d}$ design value of the axial withdrawal capacity of the threaded part of the screw
- d outer thread diameter of the screw
- l_{ef} smaller value of the penetration depth below or above the potential crack
- $F_{t,Rd}$ design value of the tensile resistance of the screw = $f_{tens,d}$

Outside of the connections loaded perpendicular to the grain, only one row of screws per side may be considered in the beam's longitudinal direction.

¹⁹ The information given in this Annex is not based on an assessment according to the provisions of the EAD which is used as basis for the issuing of this ETA and is, thus, also not based on an agreement within EOTA. It is not linked to any provision of Regulation (EU) No. 2024/3110 of the European Parliament and of the Council of 27 November 2024 laying down harmonised rules for the marketing of construction products and repealing Regulation (EU) No 305/2011 and cannot be used when drawing up a declaration of performance and conformity according to this Regulation.

Würth self-tapping screws	Annex A.4
Tensile reinforcement perpendicular to grain (informative)	

English translation prepared by DIBt

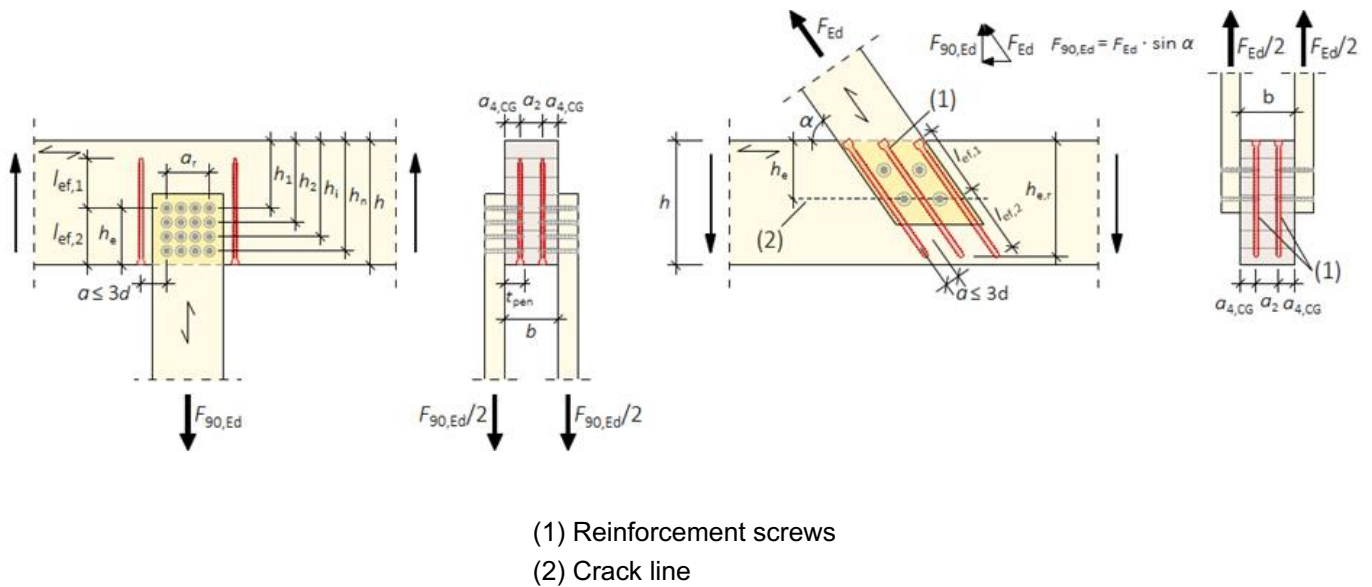

Figure A.4.1: Example of reinforcement for connections, loaded perpendicular to the grain, applied load downward (left), upward (right)

Würth self-tapping screws	Annex A.4
Tensile reinforcement perpendicular to grain (informative)	

English translation prepared by DIBt

A.4.2.2 Notched beam supports

The axial capacity of a reinforcement of a notched beam support shall fulfil the following condition:

$$\frac{1.3 \cdot V_d \cdot [3 \cdot (1 - \alpha)^2 - 2 \cdot (1 - \alpha)^3]}{F_{ax,Rd}} \leq 1 \quad (4.2)$$

Where

V_d design value of the shear force

$\alpha = h_e/h$

h = member depth

$F_{ax,Rd} = \min \{ f_{ax,d} \cdot d \cdot l_{ef}; F_{t,Rd} \}$

$f_{ax,d}$ design value of the axial withdrawal capacity of the threaded part of the screw

d outer thread diameter of the screw

l_{ef} smaller value of the penetration depth below or above the potential crack, the total minimum penetration depth of the screw shall be $2 \cdot l_{ef}$

$F_{t,Rd}$ design value of the tensile resistance of the screws = $f_{tens,d}$

Only one row of screws may be considered in the beam's longitudinal direction.

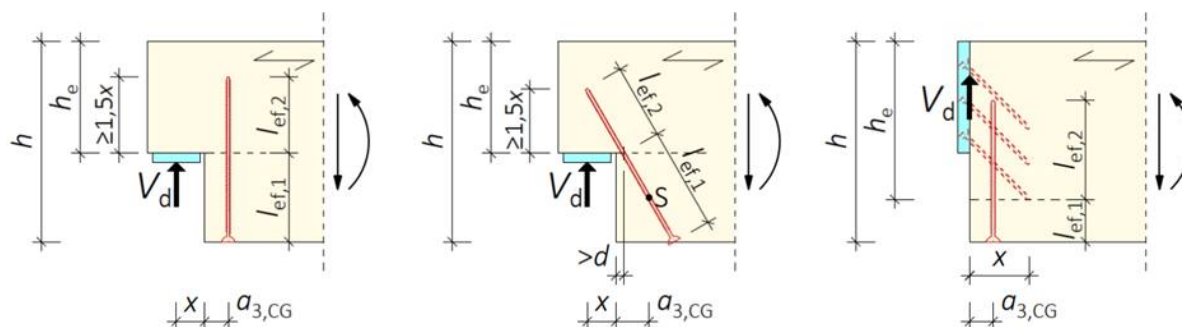

Figure A.4.2: Reinforced notches with fully threaded screws arranged perpendicular to the grain (a) and inclined to the grain (b). A plate connected at the end (c) should be verified like a notch.

Würth self-tapping screws	Annex A.4
Tensile reinforcement perpendicular to grain (informative)	

English translation prepared by DIBt

A.5 Shear reinforcement (informative)²⁰

A.5.1 General

Only fully threaded Würth "ASSY" and "ASSY plus VG" screws with $d \geq 8$ mm may be used for shear reinforcement of timber members. The provisions are valid for straight beams with constant rectangular cross-section.

The screws shall be driven into the timber member under an angle between the screw axis and the grain direction of 45° .

The provisions regarding shear reinforcement are valid for the following timber members:

- Glued laminated timber made of softwood and
- Glued solid timber made of softwood.

A minimum number of four screws shall be arranged in a line parallel to the grain as shear reinforcement. The spacing between the screws in a line parallel to the grain shall not exceed the depth h of the timber member.

For spacing, end and edge distances of the screws the provisions in Annex A.2.4 apply.

If the screws are arranged in one line parallel to the grain, it shall be done centrally in relation to the beam width.

Outside reinforced areas the shear design shall fulfil the conditions for unreinforced timber members.

For the design and construction of the shear reinforcement of timber members perpendicular to the grain, the provisions at the place of installation shall apply.

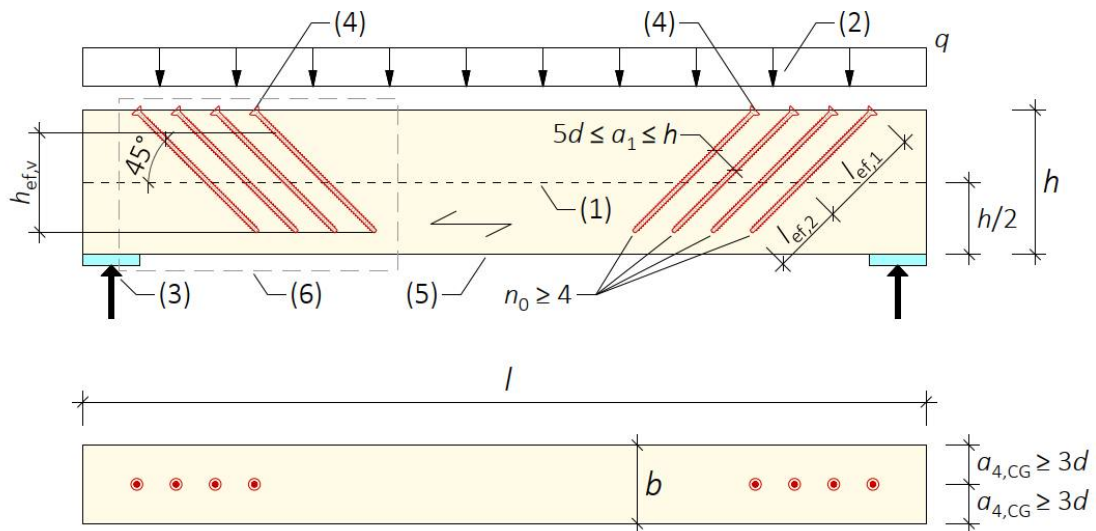

(1) Crack line; (2) Line load; (3) Compressive force on the beam; (4) Reinforcement screws; (5) Glued solid timber (GST) or glued laminated timber (GLT) from softwood; (6) Reinforced area

Figure A.5.1: Principle of a shear reinforced beam using screws

²⁰ The information given in this Annex is not based on an assessment according to the provisions of the EAD which is used as basis for the issuing of this ETA and is, thus, also not based on an agreement within EOTA. It is not linked to any provision of Regulation (EU) No. 2024/3110 of the European Parliament and of the Council of 27 November 2024 laying down harmonised rules for the marketing of construction products and repealing Regulation (EU) No 305/2011 and cannot be used when drawing up a declaration of performance and conformity according to this Regulation.

Würth self-tapping screws	Annex A.5
Shear reinforcement (informative)	

English translation prepared by DIBt

A.5.2 Design

The provisions are valid for concentrated and linear loads.

For shear in reinforced areas of timber members specified in Annex A.5.1 with a stress component parallel to the grain, the following expression shall be satisfied:

$$\tau_d \leq f_{v,mod,d} = f_{v,d} \cdot \min \left\{ 1.3; \frac{k_\tau}{\eta_H} \right\} \quad (5.1)$$

where

τ_d design shear stress [N/mm²]
 $f_{v,d}$ design shear strength [N/mm²]
 $k_\tau = 1 - 0.46 \cdot \sigma_{90,d} - 0.052 \cdot \sigma_{90,d}^2$ [N/mm²] (5.2)

$\sigma_{90,d}$ design stress perpendicular to the grain (negative value for compression) [N/mm²]
 $\sigma_{90,d} = \frac{n_{90} \cdot F_{ax,d}}{\sqrt{2} \cdot b \cdot a_1}$ [N/mm²] (5.3)

b width of the timber member [mm]
 a_1 distance between screws perpendicular to the screw axis when arranged in a row [mm]
 $F_{ax,d} = \frac{\sqrt{2} \cdot (1 - \eta_H) \cdot V_d \cdot a_1}{n_{90} \cdot h_{ef,v}}$ (5.4)

$$\eta_H = \frac{G \cdot b}{G \cdot b + \frac{1}{2 \cdot \sqrt{2} \left(\frac{6 \cdot a_1}{n_{90} \left(\pi \cdot d \cdot h_{ef,v}^2 \cdot k_{ax} \right) + \frac{a_1}{EA_S}} \right)}} \quad (5.5)$$

- V_d design shear force [N]
 d outer thread diameter of the screw [mm]
 $h_{ef,v}$ depth of the shear-reinforced area of the timber member [mm]
 G mean value of shear modulus [N/mm²]
 n_{90} is the number of rows of screws within the member width b . Multiple rows of screws should be arranged evenly and symmetrically across the member width b .
 k_{ax} connection stiffness between screw and timber member [N/mm³]
 $k_{ax} = 400 \cdot d^{-0,8} \cdot l_{ef}^{-0,6} \cdot \rho_m^{0,2}$ for fully threaded "ASSY plus VG" and fully threaded "ASSY" screws with $d \geq 8$ mm
 ρ_m mean density of the timber member [kg/m³]
 $E \cdot A_S$ Axial stiffness of one screw

$$E \cdot A_S = \frac{E \cdot \pi \cdot d_1^2}{4} \quad (5.6)$$

- E modulus of elasticity, $E = 210.000$ N/mm²
 d_1 inner thread diameter of the screw [mm]

Würth self-tapping screws	Annex A.5
Shear reinforcement (informative)	

English translation prepared by DIBt

The axial capacity of a Würth "ASSY plus VG" screw shall fulfil the following condition:

$$\frac{F_{ax,d}}{F_{ax,Rd}} \leq 1 \quad (5.7)$$

where

$$F_{ax,Rd} = \min \left\{ \begin{array}{l} f_{ax,d} \cdot d \cdot \ell_{ef} \\ f_{tens,d} \end{array} \right.$$

- $f_{ax,d}$ design value of the axial withdrawal parameter capacity of the threaded part of the screw [N/mm²]
 ℓ_{ef} Anchorage length or threaded length of the screw above or below the crack plane at the beam midspan [mm]
 $f_{tens,d}$ design tensile strength of the screw [N]

Würth self-tapping screws	Annex A.5
Shear reinforcement (informative)	

English translation prepared by DIBt

A.6 Reinforcement of connections with laterally loaded dowel-type fasteners (informative)²¹

Unless specified otherwise in national provisions that apply at the installation site, the axial capacity of a reinforcement of a steel-to-timber or timber-to-timber connection with laterally loaded dowel-type fasteners loaded by a connection force parallel to the grain shall fulfil the following condition:

$$\frac{0.3 \cdot F_{v,0,Ed}}{F_{ax,Rd}} \leq 1 \tag{6.1}$$

Where

$F_{v,0,Ed}$ Design value of force per fastener and shear plane parallel to the grain [N],

$F_{ax,Rd}$ Minimum of the design values of the withdrawal capacity and the tensile capacity of the reinforcing fully threaded screws where l_{ef} is the smaller value of the penetration depth at the screw tip or head (see Figure A.6.1)

If each timber member under each fastener in a connection is reinforced, the effective number n_{ef} according to EN 1995-1-1, equation (8.34) may be taken as $n_{ef} = n$.

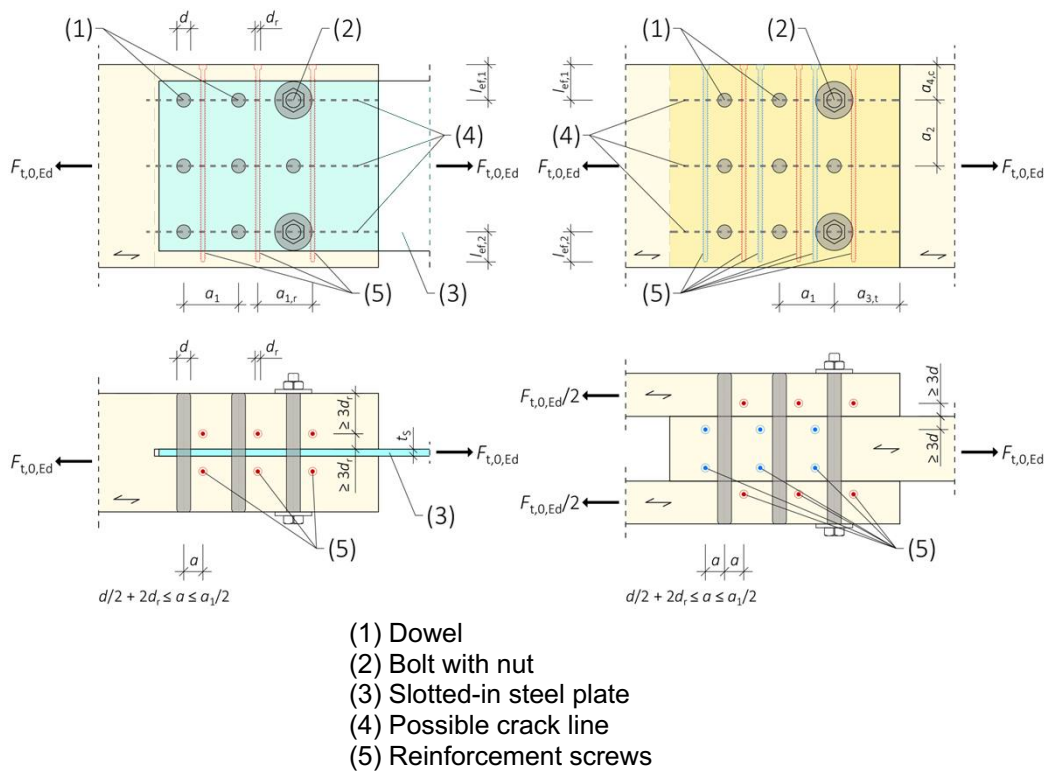

Figure A.6.1: Dowel/bolt connection with reinforcement screws

²¹ The information given in this Annex is not based on an assessment according to the provisions of the EAD which is used as basis for the issuing of this ETA and is, thus, also not based on an agreement within EOTA. It is not linked to any provision of Regulation (EU) No. 2024/3110 of the European Parliament and of the Council of 27 November 2024 laying down harmonised rules for the marketing of construction products and repealing Regulation (EU) No 305/2011 and cannot be used when drawing up a declaration of performance and conformity according to this Regulation.

Würth self-tapping screws	Annex A.6
Reinforcement of connections with laterally loaded dowel-type fasteners (informative)	

English translation prepared by DIBt

A.7 Fastening of thermal insulation material on top of rafters (informative)²²

A.7.1 General

Würth screws with an outer thread diameter of at least 6 mm may be used for the fixing of thermal insulation material on top of rafters or on wood-based members in vertical façades. In the following, the meaning of the word rafter includes wood-based members with inclinations between 0° and 90°.

The thickness of the thermal insulation material may be up to 400 mm. The thermal insulation material shall be applicable as insulation on top of rafters or for façades according to national provisions that apply at the installation site.

The battens have to be from solid timber according to EN 338/EN 14081-1. The minimum thickness t and the minimum width b of the battens are given in Table A.7.1:

Table A.7.1 Minimum thickness and minimum width of the battens

Outer thread diameter [mm]	Minimum thickness t [mm]	Minimum width b [mm]
6 / 6.5 / 7 and 8	30	50
10	40	60
12	80	100
14	100	100

The minimum width of the rafters shall be 60 mm.

The spacing between screws shall be not more than 1.75 m.

Friction forces shall not be considered for the design of the characteristic axial load of the screws.

The anchorage of wind suction forces as well as the bending stresses of the battens shall be considered for design. Screws perpendicular to the grain of the rafter (angle $\alpha = 90^\circ$) may be arranged where required considering the design of the battens.

A.7.2 Parallel inclined screws and thermal insulation material in compression

A.7.2.1 Mechanical model

The system of rafter, thermal insulation material on top of rafter and counter battens parallel to the rafter may be considered as a beam on elastic foundation. The counter batten represents the beam, and the thermal insulation material on top of the rafter the elastic foundation. The minimum compressive stress of the thermal insulation material at 10% deformation, measured according to EN 826²³, shall be $\sigma_{(10\%)} = 0.05 \text{ N/mm}^2$. The counter batten is loaded perpendicular to the axis by point loads F_b transferred by regularly spaced battens. Further point loads F_s are caused by the shear load of the roof due to dead and snow load, which are transferred from the screw heads into the counter battens.

Instead of battens the following wood-based panels may be used to cover the thermal insulation material if they are suitable for that use:

- Plywood according to EN 636 and EN 13986,
- Oriented Strand Board, OSB according to EN 300 and EN 13986,
- Particleboard according to EN 312 and EN 13986
- Fibreboards according to EN 622-2, EN 622-3 and EN 13986.

²² The information given in this Annex is not based on an assessment according to the provisions of the EAD which is used as basis for the issuing of this ETA and is, thus, also not based on an agreement within EOTA. It is not linked to any provision of Regulation (EU) No. 2024/3110 of the European Parliament and of the Council of 27 November 2024 laying down harmonised rules for the marketing of construction products and repealing Regulation (EU) No 305/2011 and cannot be used when drawing up a declaration of performance and conformity according to this Regulation.

²³ EN 826:2013 Thermal insulating products for building applications - Determination of compression behaviour

Würth self-tapping screws	Annex A.7
Fastening of thermal insulation material on top of rafters (informative)	

English translation prepared by DIBt

Only screws with countersunk head, 75 ° head, FBS head or woodwork head shall be used for fixing wood-based panels on rafters with thermal insulation material as interlayer.

The minimum thickness of the wood-based panels shall be 22 mm.

The word batten includes the meaning of the above-mentioned wood-based panels in the following.

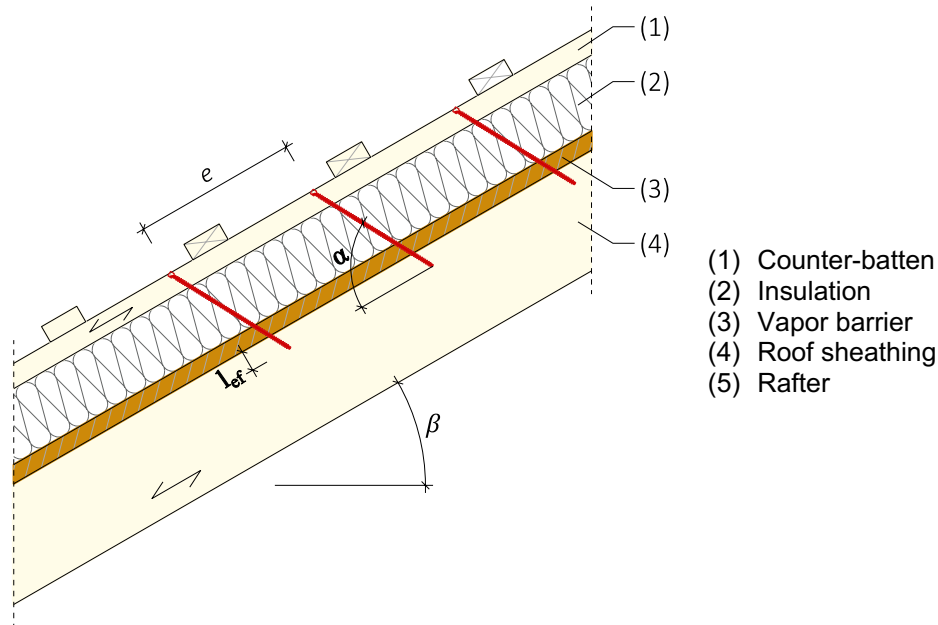

Figure A.7.1: Fastening of the thermal insulation material on top of rafters

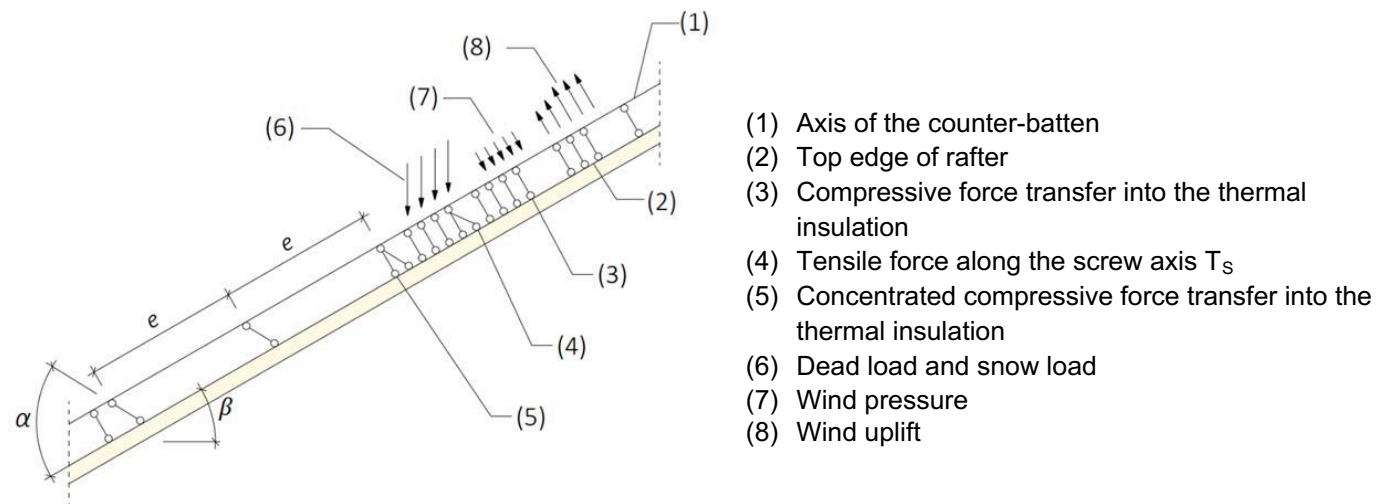

Figure 7.2: Structural model for parallel inclined screws

Würth self-tapping screws	Annex A.7
Fastening of thermal insulation material on top of rafters (informative)	

English translation prepared by DIBt

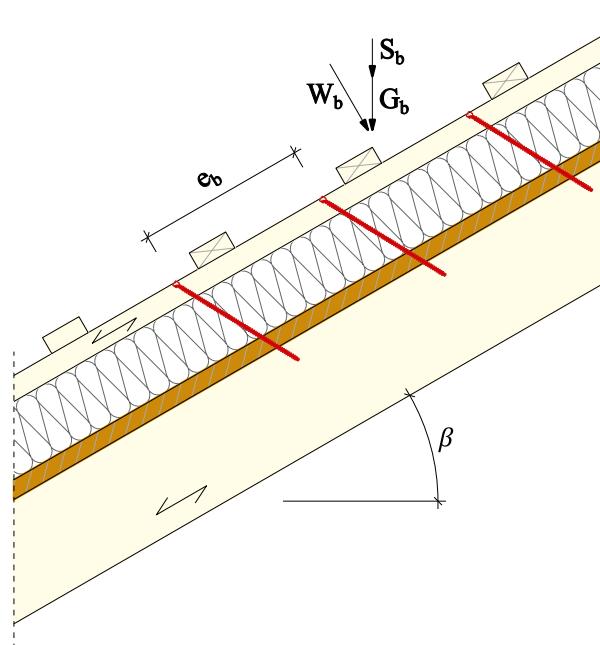

Figure A.7.3: Point loads F_b perpendicular to the battens

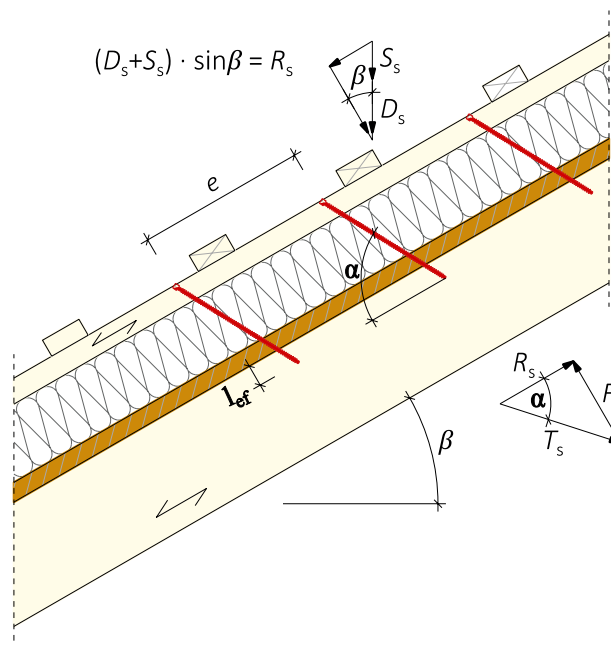

Figure A.7.4: Point loads F_s perpendicular to the battens, load application in the area of the screw heads

Würth self-tapping screws	Annex A.7
Fastening of thermal insulation material on top of rafters (informative)	

English translation prepared by DIBt

A.7.2.2 Design of the battens

It's assumed that the spacing between the counter battens exceeds the characteristic length l_{char} .

The characteristic values of the bending stresses are calculated as:

$$M_k = \frac{(F_{b,k} + F_{s,k}) \cdot l_{char}}{4} \quad (7.1)$$

Where

$$l_{char} = \text{characteristic length} \quad l_{char} = \sqrt[4]{\frac{4 \cdot EI}{w_{ef} \cdot K}} \quad (7.2)$$

EI = bending stiffness of the batten

K = coefficient of subgrade

w_{ef} = effective width of the thermal insulation material

$F_{b,k}$ = point loads perpendicular to the battens

$F_{s,k}$ = point loads perpendicular to the battens, load application in the area of the screw heads

The coefficient of subgrade K may be calculated from the modulus of elasticity E_{HI} and the thickness t_{HI} of the thermal insulation material if the effective width w_{ef} of the thermal insulation material under compression is known. Due to the load extension in the thermal insulation material the effective width w_{ef} is greater than the width of the batten or rafter, respectively. For further calculations, the effective width w_{ef} of the thermal insulation material may be determined according to:

$$w_{ef} = w + t_{HI}/2 \quad (7.3)$$

where

w = minimum from width of the batten or rafter, respectively

t_{HI} = thickness of the thermal insulation material

$$K = \frac{E_{HI}}{t_{HI}} \quad (7.4)$$

The following condition shall be satisfied:

$$\frac{\sigma_{m,d}}{f_{m,d}} = \frac{M_d}{W \cdot f_{m,d}} \leq 1 \quad (7.5)$$

For the calculation of the section modulus W the net cross section shall be considered.

The characteristic values of the shear stresses shall be calculated according to:

$$V_k = \frac{(F_{b,k} + F_{s,k})}{2} \quad (7.6)$$

The following condition need to be satisfied:

$$\frac{\tau_d}{f_{v,d}} = \frac{1.5 \cdot V_d}{A \cdot f_{v,d}} \leq 1 \quad (7.7)$$

For the calculation of the cross-section area the net cross section shall be considered.

Würth self-tapping screws	Annex A.7
Fastening of thermal insulation material on top of rafters (informative)	

English translation prepared by DIBt

A.7.2.3 Design of the thermal insulation material

The characteristic value of the compressive stresses in the thermal insulation material shall be calculated according to:

$$\sigma_k = \frac{1.5 \cdot F_{b,k} + F_{s,k}}{2 \cdot l_{char} \cdot w} \quad (7.8)$$

The design value of the compressive stress shall not be greater than 110% of the compressive strength at 10% deformation calculated according to EN 826.

A.7.2.4 Design of the screws

The screws are loaded predominantly axial. The characteristic value of the axial tension force in the screw may be calculated from the shear loads of the roof R_s :

$$T_{S,k} = \frac{R_{S,k}}{\cos \alpha} \quad (7.9)$$

The load-carrying capacity of axially loaded screws is the minimum design value of the axial withdrawal capacity of the threaded part of the screw, the head pull-through capacity of the screw and the tensile capacity of the screw according to Annex 2.

In order to limit the deformation of the screw head for thermal insulation material with thickness over 220 mm or with compressive strength below 0.12 N/mm², respectively, the axial withdrawal capacity of the screws shall be reduced by the factors k_1 and k_2 :

$$F_{ax,\alpha,Rd} = \min \left\{ \frac{k_{ax} \cdot f_{ax,d} \cdot d \cdot l_{ef} \cdot k_1 \cdot k_2}{k_\beta} \cdot \left(\frac{\rho_k}{350} \right)^{0.8}; f_{head,d} \cdot d_h^2 \cdot \left(\frac{\rho_k}{350} \right)^{0.8}; \frac{f_{tens,k}}{\gamma_{M2}} \right\} \quad (7.10)$$

where:

k_{ax}	Factor according to Annex A.2.3.2, taking into account the angle α between screw axis and grain direction
$f_{ax,d}$	design value of the axial withdrawal parameter of the threaded part of the screw in the rafter [N/mm ²]
d	outer thread diameter of the screw [mm]
l_{ef}	penetration length of the threaded part of the screw in the rafter [mm], $l_{ef} \geq 40$ mm
ρ_k	characteristic density of the wood-based member [kg/m ³], for beech, ash and oak $\rho_k \leq 590$ kg/m ³ and for LVL (softwood) $\rho_k \leq 500$ kg/m ³
α	angle α between screw axis and grain direction, $30^\circ \leq \alpha \leq 90^\circ$
$f_{head,d}$	design value of the head pull-through parameter of the screw [N/mm ²]
d_h	head diameter of the screw [mm]
$f_{tens,k}$	characteristic tensile capacity of the screw according to Annex 2 [N]
γ_{M2}	partial factor according to EN 1993-1-1 in conjunction with the particular national annex
k_1	$\min \{1; 220/t_{HI}\}$
k_2	$\min \{1; \sigma_{10\%}/0.12\}$
t_{HI}	thickness of the thermal insulation material [mm]
$\sigma_{10\%}$	compressive stress of the thermal insulation material under 10% deformation [N/mm ²]
k_β	Factor according to Annex A.2.3.2

If equation (7.10) is fulfilled, the deflection of the battens does not need to be considered when designing the load-carrying capacity of the screws.

Würth self-tapping screws	Annex A.7
Fastening of thermal insulation material on top of rafters (informative)	

English translation prepared by DIBt

A.7.3 Alternatively inclined screws and thermal insulation material non in compression

A.7.3.1 Mechanical model

Depending on the screw spacing and the arrangement of tensile and compressive screws with different inclinations the battens are loaded by significant bending moments. The bending moments are derived based on the following assumptions:

- The tensile and compressive loads in the screws are determined based on equilibrium conditions from the actions parallel and perpendicular to the roof plane. These actions are constant line loads q_{\perp} and q_{\parallel} .
- The screws act as hinged columns supported 10 mm within the batten or rafter, respectively. The effective column length consequently equals the length of the screw between batten and rafter plus 20 mm.

The batten is considered as a continuous beam with a constant span $l = A + B$. The compressive screws constitute the supports of the continuous beam while the tensile screws transfer concentrated loads perpendicular to the batten axis.

The screws are predominantly loaded in withdrawal or compression, respectively. The characteristic values of the screw's normal forces are determined based on the loads parallel and perpendicular to the roof plane:

Compressive screw:

$$N_{c,k} = (A + B) \cdot \left(-\frac{q_{\parallel,k}}{\cos \alpha_1 + \sin \alpha_1 / \tan \alpha_2} - \frac{q_{\perp,k} \cdot \sin(90^\circ - \alpha_2)}{\sin(\alpha_1 + \alpha_2)} \right) \quad (7.11)$$

Tensile screw:

$$N_{t,k} = (A + B) \cdot \left(\frac{q_{\parallel,k}}{\cos \alpha_2 + \sin \alpha_2 / \tan \alpha_1} - \frac{q_{\perp,k} \cdot \sin(90^\circ - \alpha_1)}{\sin(\alpha_1 + \alpha_2)} \right) \quad (7.12)$$

- A distance of the screws according to Figure A.7.5
 B distance of the alternatively inclined screws according to Figure A.7.5
 $q_{\parallel,k}$ characteristic value of the loads parallel to the roof plane
 $q_{\perp,k}$ characteristic value of the loads perpendicular to the roof plane
 α angle α_1 and α_2 between screw axis and grain direction, $30^\circ \leq \alpha_1 \leq 90^\circ$, $30^\circ \leq \alpha_2 \leq 90^\circ$

Only screws with full thread or a thread below the head and in the area of the drill tip shall be used.

The bending moments in the batten follow from the constant line load q_{\perp} and the load components perpendicular to the batten from the tensile screws. The span of the continuous beam is $(A + B)$. The characteristic value of the load component perpendicular to the batten from the tensile screw is:

$$F_{zS,k} = (A + B) \cdot \left(\frac{q_{\parallel,k}}{1/\tan \alpha_1 + 1/\tan \alpha_2} - \frac{q_{\perp,k} \cdot \sin(90^\circ - \alpha_1) \cdot \sin \alpha_2}{\sin(\alpha_1 + \alpha_2)} \right) \quad (7.13)$$

A positive value for $F_{zS,k}$ means a load towards the rafter, a negative value a load away from the rafter. The system of the continuous beam is shown in Figure A.7.5.

The battens or wood-based panels fixed on the rafter shall be supported perpendicular to the load-bearing plane.

Würth self-tapping screws	Annex A.7
Fastening of thermal insulation material on top of rafters (informative)	

English translation prepared by DIBt

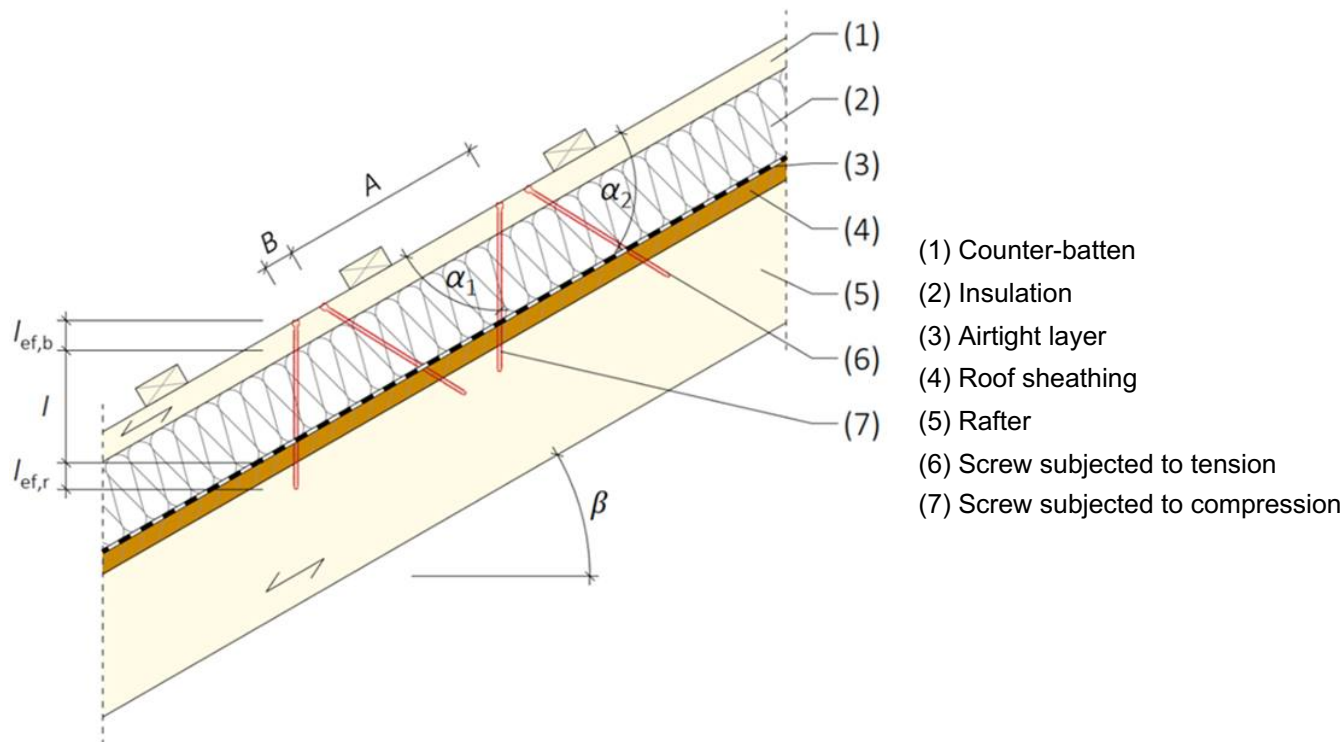

Figure A.7.5: Fastening of thermal insulation material on top of rafters - structural system for alternatively inclined screws

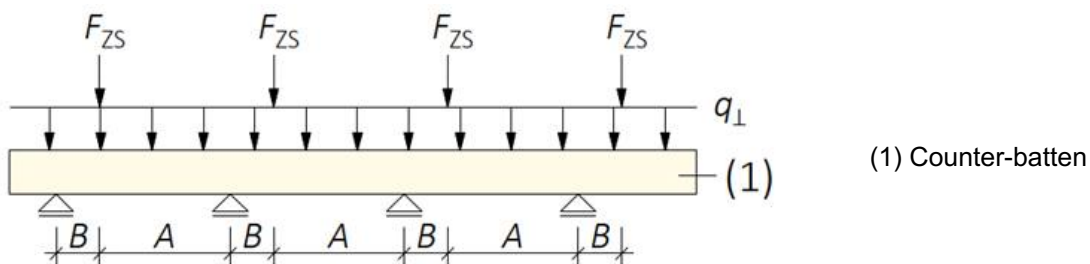

Figure A.7.6: Continuous batten under constant line loads from actions on the roof plane q_{\perp} and concentrated loads from tensile screws F_{ZS}

Würth self-tapping screws	Annex A.7
Fastening of thermal insulation material on top of rafters (informative)	

English translation prepared by DIBt

A.7.3.2 Design of the screws

The design value of the load-carrying capacity of the screws shall be calculated according to equations (7.14) and (7.15).

Screws loaded in tension:

$$F_{ax,\alpha,Rd} = \min \left\{ \frac{k_{ax} \cdot f_{ax,d} \cdot d \cdot l_{ef,b}}{k_{\beta}} \cdot \left(\frac{\rho_{b,k}}{350} \right)^{0.8}; \frac{k_{ax} \cdot f_{ax,d} \cdot d \cdot l_{ef,r}}{k_{\beta}} \cdot \left(\frac{\rho_{r,k}}{350} \right)^{0.8}; \frac{f_{tens,k}}{\gamma_{M2}} \right\} \quad (7.14)$$

Screws loaded in compression:

$$F_{ax,\alpha,Rd} = \min \left\{ \frac{k_{ax} \cdot f_{ax,d} \cdot d \cdot l_{ef,b}}{k_{\beta}} \cdot \left(\frac{\rho_{b,k}}{350} \right)^{0.8}; \frac{k_{ax} \cdot f_{ax,d} \cdot d \cdot l_{ef,r}}{k_{\beta}} \cdot \left(\frac{\rho_{r,k}}{350} \right)^{0.8}; \frac{\kappa_c \cdot N_{pl,k}}{\gamma_{M1}} \right\} \quad (7.15)$$

where:

k_{ax}	Factor according to Annex A.2.3.2, taking into account the angle α between screw axis and grain direction
$f_{ax,d}$	design value of the axial withdrawal capacity of the threaded part of the screw [N/mm ²]
d	outer thread diameter of the screw [mm]
$l_{ef,b}$	penetration length of the threaded part of the screw in the batten [mm]
$l_{ef,r}$	penetration length of the threaded part of the screw in the rafter, $l_{ef} \geq 40$ mm
k_{β}	Factor according to Annex A.2.3.2
$\rho_{b,k}$	characteristic density of the batten [kg/m ³], for beech, ash and oak $\rho_k \leq 590$ kg/m ³ and for LVL (softwood) $\rho_k \leq 500$ kg/m ³
$\rho_{r,k}$	characteristic density of the rafter [kg/m ³], for beech, ash and oak $\rho_k \leq 590$ kg/m ³ and for LVL (softwood) $\rho_k \leq 500$ kg/m ³
α	angle α_1 or α_2 between screw axis and grain direction, $30^\circ \leq \alpha_1 \leq 90^\circ$, $30^\circ \leq \alpha_2 \leq 90^\circ$
$f_{tens,k}$	characteristic tensile capacity of the screw according to Annex A.2 [N]
γ_{M1}, γ_{M2}	partial factor according to EN 1993-1-1 in conjunction with the particular national Annex
$\kappa_c \cdot N_{pl,k}$	Buckling capacity of the screw according to table A.7.2 [N]

Würth self-tapping screws	Annex A.7
Fastening of thermal insulation material on top of rafters (informative)	

English translation prepared by DIBt

Table A.7.2 Characteristic load-carrying capacity of the screws $\kappa_c \cdot N_{pl,k}$ in kN

Free screw length l between batten and rafter [mm]	ASSY plus VG or ASSY VGN					ASSY Isotop
	Outer thread diameter d [mm]					
	6.0	8.0	10.0	12.0	14.0	8.0/ 10.0
	$\kappa_c \cdot N_{pl,k}$ [kN]					
≤ 100	1.11	3.21	8.07	12.9	21.0	10.1
120	0.84	2.45	6.27	10.2	16.9	8.30
140	0.66	1.93	4.99	8.19	13.7	6.84
160	0.53	1.56	4.05	6.70	11.3	5.70
180	0.43	1.28	3.35	5.57	9.48	4.79
200	-	1.07	2.82	4.69	8.03	4.08
220	-	0.91	2.41	4.01	6.89	3.51
240	-	0.78	2.08	3.48	5.96	3.04
260	-	0.68	1.81	3.03	5.21	2.67
280	-	0.59	1.59	2.66	4.61	2.35
300	-	0.53	1.40	2.36	4.09	2.10
320	-	0.47	1.25	2.10	3.65	1.88
340	-	0.42	1.12	1.89	3.28	1.69
360	-	0.37	1.01	1.70	2.96	1.53
380	-	0.34	0.92	1.55	2.69	1.45
400	-	0.31	0.83	1.41	2.45	1.26
420	-	0.28	0.76	1.29	2.25	1.16
440	-	0.26	0.70	1.18	2.06	1.06
460	-	0.24	0.65	1.09	1.90	0.99
480	-	0.22	0.60	1.01	1.76	0.91

Würth self-tapping screws	Annex A.7
Fastening of thermal insulation material on top of rafters (informative)	

English translation prepared by DIBt

A.8 Effective number of screws (informative) ²⁴

A.8.1 Effective number of screws under axial stress

Table A.8.1 Effective number of screws under axial stress

Transverse tension, transverse compression, shear reinforcement and load transfer		
	$n_{ef} = n$	(8.1a)
Continuous connections and continuous load transfers (e.g. reinforcement of wood-based members, fastening of thermal insulation material on top of rafters)		
	$n_{ef} = n$	(8.1b)
Wood-wood and wood-based panel-wood connections		
Per fastener group with $n \leq 10$	$n_{ef} = n$	(8.1c)
Per fastener group with $n > 10$	$n_{ef} = 0.9 \cdot n$	(8.1d)
Wood-wood and wood-based panel-wood connections with pairs of intersecting screws with corresponding screws subjected to tensile or compressive stress - n_x is the number of screw crosses or pairs		
For $n_x \leq 10$	$n_{ef} = n_x$	(8.1e)
For $n_x > 10$	$n_{ef} = n_x^{0.9}$	(8.1f)
Steel-to-timber connections		
For each fastener group with $30^\circ \leq \delta \leq 60^\circ$ in shear connections with inclined, axially loaded screws δ = angle between the screw axis and the shear plane	$n_{ef} = 0.9 \cdot n$	(8.1g)
For all other steel-to-timber connections	$n_{ef} = n^{0.9}$	(8.1h)

²⁴ The information given in this Annex is not based on an assessment according to the provisions of the EAD which is used as basis for the issuing of this ETA and is, thus, also not based on an agreement within EOTA. It is not linked to any provision of Regulation (EU) No. 2024/3110 of the European Parliament and of the Council of 27 November 2024 laying down harmonised rules for the marketing of construction products and repealing Regulation (EU) No 305/2011 and cannot be used when drawing up a declaration of performance and conformity according to this Regulation.

Würth self-tapping screws	Annex A.8
Effective number of screws n_{ef} arranged under an angle $30^\circ \leq \alpha \leq 60^\circ$ between the shear plane and the screw axis (informative)	

English translation prepared by DIBt

A.8.2 Effective number of screws arranged under an angle between the shear plane and the screw axis

Alternatively to Table A.8.1, the load-carrying capacity may be calculated using the effective number of fasteners n_{ef} for one row of n inclined screws or crossed screw couples in timber-to-timber or steel-to-timber single shear connections parallel to the load, where the screws are arranged under an angle $30^\circ \leq \alpha \leq 60^\circ$ between the shear plane and the screw axis:

$$n_{ef} = \frac{1}{\max\{\delta_1; \delta_2\}} \quad (8.2)$$

Where:

$$\delta_1 = 1 - m_1 \cdot (1 + \mu) + \mu + \frac{m_1 - m_2}{m_1^n - m_2^n} \cdot (m_1^n \cdot (1 + \mu) - \mu) \quad (8.3)$$

$$\delta_2 = -\mu + m_1^{n-1} \cdot (1 + \mu) - \frac{m_1^{n-1} - m_2^{n-1}}{m_1^n - m_2^n} \cdot (m_1^n \cdot (1 + \mu) - \mu) \quad (8.4)$$

$$\mu = -\frac{1}{1 + \frac{E_1 \cdot A_1}{E_2 \cdot A_2}} \quad (8.5)$$

$E_1 A_1$ Axial stiffness of side member 1

$E_2 A_2$ Axial stiffness of side or middle member 2. If member 2 is a middle member, A_2 is only half of the member cross-section

E_1, E_2 Mean value of modulus of elasticity of member 1 and member 2

A_1, A_2 Cross-sectional area of member 1 and member 2

K_u Slip modulus parallel to the shear plane per screw (inclined screws) or per screw couple (crossed screws) for the ultimate limit state

n Number of inclined screws or crossed screw couples per row

m Number of rows of inclined screws or crossed screw couples per shear plane

$$m_1 = 0.5 \cdot (\omega + \sqrt{\omega^2 - 4}) \quad (8.6)$$

$$m_2 = 0.5 \cdot (\omega - \sqrt{\omega^2 - 4}) \quad (8.7)$$

$$\omega = 2 + K_u \cdot a_1 \left(\frac{m}{E_1 \cdot A_1} + \frac{m}{E_2 \cdot A_2} \right) \quad (8.8)$$

a_1 Screw spacing parallel to grain

Würth self-tapping screws	Annex A.8
Effective number of screws n_{ef} arranged under an angle $30^\circ \leq \alpha \leq 60^\circ$ between the shear plane and the screw axis (informative)	

English translation prepared by DIBt

A.9 Dimensions

A.9.1 General

A.9.1.1 Dimensions of ASSY and JAMO screws (all types except ASSY plus VG and ASSY Isotop)

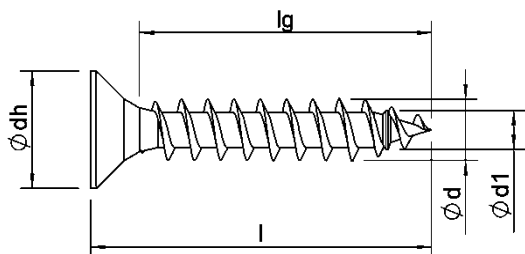

Full thread without drill tip

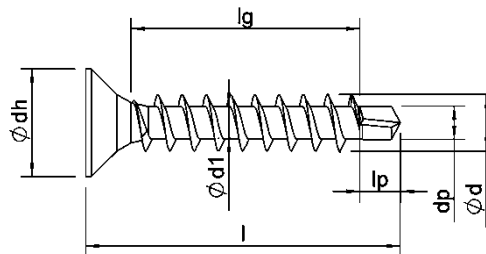

Full thread with drill point

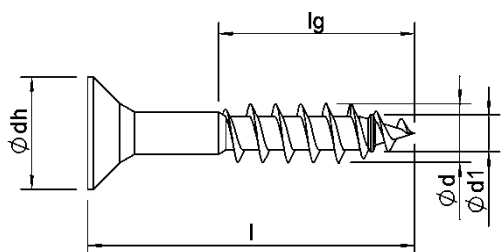

Partial thread without drill point

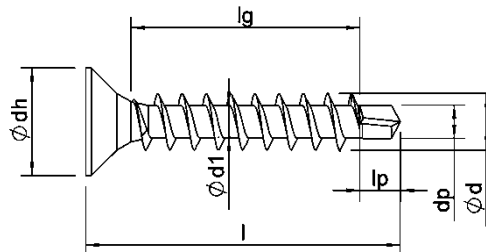

Partial thread with drill tip

All ASSY and JAMO screws have either a full thread (I), a threadless section in the middle of the screw (II), a threadless section under the head (III) or a combination (IV). There may be an indentation in the threaded section, which does not affect the load-bearing capacity.

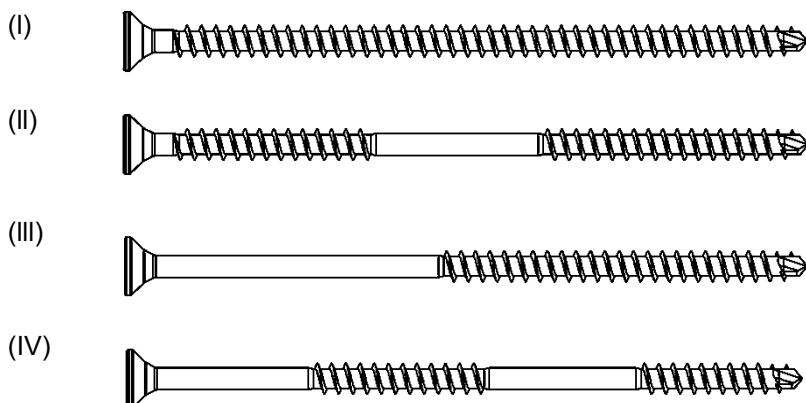

For fastening insulation materials or insulation boards with cover plates made of different materials (metal, wood, wood-based materials) at a distance from the wooden substrate to be screwed into or when screwing into dowels, the screw and thread length can be extended as required up to the maximum screw and thread length.

Würth self-tapping screws	Annex A.9
Dimensions	

English translation prepared by DIBt

A.9.1.2 Dimensions of ASSY plus VG screws

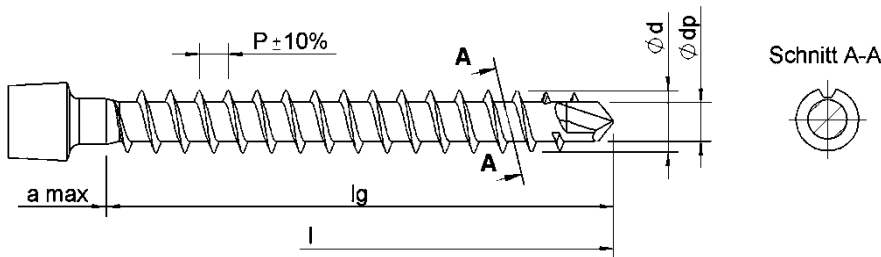

ASSY plus VG screws may have cutting notches in the thread flank according to section A-A.

Dimensions of ASSY Isotop screws

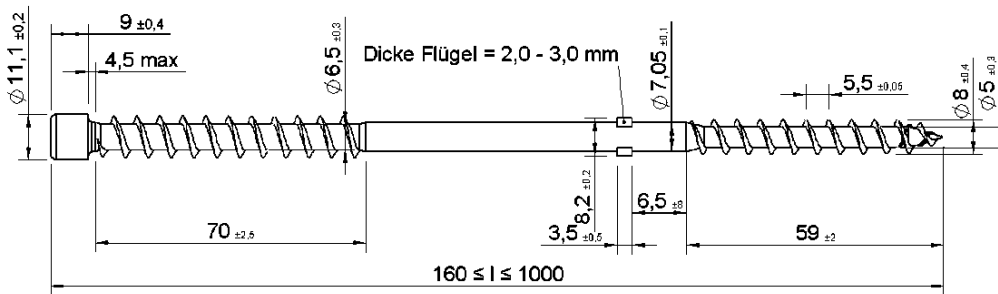

ASSY Isotop screws have a coarse thread and can be manufactured with or without a mating thread in the tip thread, as well as with or without wings. The screw heads of ASSY Isotop screws can be designed as follows.



A.9.1.3 Screw length

Depending on the type of screw head, the head height k may or may not be included in the total length l of the screw, see Screw head. Furthermore, depending on the type of screw tip, the length of the screw tip l_p may or may not be included in the thread length l_g of the screw, see Screw tip.

The thread length l_g can be manufactured to customer specifications within the specified minimum and maximum thread lengths. ASSY and ASSY plus VG screws have the following screw and thread lengths.

Würth self-tapping screws	Annex A.9
Dimensions	

English translation prepared by DIBt

Screw and thread lengths for ASSY:

d [mm]	Carbon steel		Stainless steel	
	l [mm]	l _g [mm]	l [mm]	l _g [mm]
3.0	13 ≤ l ≤ 50	12 ≤ l _g ≤ 49	13 ≤ l ≤ 50	12 ≤ l _g ≤ 49
3.4	16 ≤ l ≤ 60	12 ≤ l _g ≤ 46	16 ≤ l ≤ 60	12 ≤ l _g ≤ 46
3.5	16 ≤ l ≤ 50	14 ≤ l _g ≤ 48	16 ≤ l ≤ 60	12 ≤ l _g ≤ 48
3.9	16 ≤ l ≤ 60	12 ≤ l _g ≤ 46	16 ≤ l ≤ 60	12 ≤ l _g ≤ 46
4.0	18 ≤ l ≤ 70	16 ≤ l _g ≤ 68	18 ≤ l ≤ 70	16 ≤ l _g ≤ 64
4.4	16 ≤ l ≤ 80	14 ≤ l _g ≤ 66	16 ≤ l ≤ 80	14 ≤ l _g ≤ 66
4.5	20 ≤ l ≤ 100	18 ≤ l _g ≤ 78	20 ≤ l ≤ 80 (140*)	18 ≤ l _g ≤ 79
5.0	22 ≤ l ≤ 120	20 ≤ l _g ≤ 90	22 ≤ l ≤ 120 (300*)	20 ≤ l _g ≤ 80
5.5			25 ≤ l ≤ 120	22 ≤ l _g ≤ 90
6.0	25 ≤ l ≤ 300	24 ≤ l _g ≤ 180	26 ≤ l ≤ 200	24 ≤ l _g ≤ 120
6.3	27 ≤ l ≤ 300	25 ≤ l _g ≤ 60	27 ≤ l ≤ 300	25 ≤ l _g ≤ 60
6.5			28 ≤ l ≤ 400	26 ≤ l _g ≤ 200
7.0	30 ≤ l ≤ 300 301 ≤ l ≤ 600	28 ≤ l _g ≤ 210 85		
7.5	35 ≤ l ≤ 400	32 ≤ l _g ≤ 240	35 ≤ l ≤ 400	32 ≤ l _g ≤ 240
8.0	35 ≤ l ≤ 800	32 ≤ l _g ≤ 240	35 ≤ l ≤ 400	32 ≤ l _g ≤ 200
10.0	45 ≤ l ≤ 1000	40 ≤ l _g ≤ 300	45 ≤ l ≤ 400	40 ≤ l _g ≤ 200
12.0	60 ≤ l ≤ 520	50 ≤ l _g ≤ 360		

* For fastening insulation materials or insulation boards with cover plates made of different materials (metal, wood, wood-based materials) at a distance from the wooden substrate to be screwed into, or when screwing into dowels, the screw and thread length can be extended as required up to the maximum screw and thread length.

Screw and thread lengths for ASSY plus VG:

d [mm]	Countersunk and cylinder head			Washer, hinge, combination, threaded bolt and external hexagon head		
	l [mm]	l _(g) [mm]	a max [mm]	l [mm]	l _(g) [mm]	a max [mm]
6.0	70 ≤ l ≤ 120 130 ≤ l ≤ 300	63 ≤ l _g ≤ 113 123 ≤ l _g ≤ 285	10 12	70 ≤ l ≤ 120 130 ≤ l ≤ 300	63 ≤ l _g ≤ 113 123 ≤ l _g ≤ 285	6 8
8.0	70 ≤ l ≤ 280 290 ≤ l ≤ 450 460 ≤ l ≤ 600	59 ≤ l _g ≤ 269 279 ≤ l _g ≤ 439 446 ≤ l _g ≤ 586	14 15 20	70 ≤ l ≤ 280 290 ≤ l ≤ 450 460 ≤ l ≤ 600	59 ≤ l _g ≤ 269 279 ≤ l _g ≤ 439 446 ≤ l _g ≤ 586	8 8 14
10.0	100 ≤ l ≤ 280 290 ≤ l ≤ 450 460 ≤ l ≤ 800	88 ≤ l _g ≤ 268 278 ≤ l _g ≤ 438 445 ≤ l _g ≤ 785	18 18 20	100 ≤ l ≤ 280 290 ≤ l ≤ 450 460 ≤ l ≤ 800	88 ≤ l _g ≤ 268 278 ≤ l _g ≤ 438 445 ≤ l _g ≤ 785	15 15 20
12.0	120 ≤ l ≤ 240 250 ≤ l ≤ 350 360 ≤ l ≤ 1000	105 ≤ l _g ≤ 225 235 ≤ l _g ≤ 335 343 ≤ l _g ≤ 985	21 21 26	120 ≤ l ≤ 240 250 ≤ l ≤ 350 360 ≤ l ≤ 1000	105 ≤ l _g ≤ 225 235 ≤ l _g ≤ 335 343 ≤ l _g ≤ 985	17 21 22
14.0	120 ≤ l ≤ 200 210 ≤ l ≤ 800 810 ≤ l ≤ 2000	105 ≤ l _g ≤ 185 195 ≤ l _g ≤ 785 795 ≤ l _g ≤ 1985	22 27 27	120 ≤ l ≤ 200 210 ≤ l ≤ 800 810 ≤ l ≤ 2000	105 ≤ l _g ≤ 185 195 ≤ l _g ≤ 785 795 ≤ l _g ≤ 1985	17 22 22

Würth self-tapping screws	Annex A.9
Dimensions	

English translation prepared by DIBt

A.9.1.4 Tolerances²⁵

For ASSY and ASSY plus VG screws, the tolerances according to EAD 130118-01-0603 apply as specified in the following table.

Feature	Range		Tolerance
	>	≤	
l, l _g	10 mm	18 mm	± 1.5 mm
	18 mm	30 mm	± 1.7 mm
	30 mm	50 mm	± 2.0 mm
	50 mm	80 mm	± 2.3 mm
	80 mm	120 mm	± 2.7 mm
	120 mm	180 mm	± 3.2 mm
	180 mm	250 mm	± 3.6 mm
	250 mm	315 mm	± 4.1 mm
	315 mm	400 mm	± 4.5 mm
	400 mm	500 mm	± 4.9 mm
	500 mm	630 mm	± 5.5 mm
	630 mm	800 mm	± 6.3 mm
	800 mm	1000 mm	± 7.0 mm
	1000 mm	1250 mm	± 8.3 mm
1250 mm	-	± 9.3 mm	
d ₁ , d, d _s	2.4 mm	6 mm	± 0.3 mm
	6 mm	24 mm	± 5
d _h	-	8 mm	± 0.5 mm
	8 mm	12 mm	± 0.6 mm
	12 mm	-	± 5
p	all		± 10

Due to the possible positive tolerance of the screw length, the screw length should be chosen so that the minimum member thickness is greater than the selected screw length. This prevents the screw tip from protruding from the member. For example, for a member thickness of 300 mm, a maximum screw length of 280 mm is recommended.

²⁵ corresponds to EAD 130118-01-0304

Würth self-tapping screws	Annex A.9
Dimensions	

English translation prepared by DIBt

A.9.2 Screw head

<p>Head type A Disc/plate head I /Back wall head</p>	<p>Head type B Disc/cup head II</p>	<p>Head type C Disc/plate head III</p>	<p>Head type D Flat head</p>	<p>Head type E Hinge head</p>	<p>Head type F Cylinder head</p>
<p>Head type G Stepped head</p>	<p>Head type H Countersunk head with/without milled pockets</p>	<p>Head type I Countersunk head with milled edges</p>	<p>Head type J Wood construction head with milled edges</p>	<p>Head type K Countersunk head 75°</p>	<p>Head type L Wood construction head 60°</p>
<p>Head type M Countersunk head with hole</p>	<p>Head type N Top head</p>	<p>Head type O Top Head II</p>	<p>Head type P FBS head</p>	<p>Head type Q Spengler head</p>	<p>Head type R Jamokopf</p>
<p>Head type S Pan head</p>	<p>Head type T Elmo head</p>	<p>Head type U Beam shoe head</p>	<p>Head type V Hexagon head with/without flange</p>	<p>Head type W Combination head with/without flange</p>	<p>Head type X External hexagonal round head</p>
<p>Head type Y Threaded bolt head</p>	<p>Head type Z Flat head with hexagon</p>				

Würth self-tapping screws	Annex A.9
Dimensions	

English translation prepared by DIBt

Type A Disc/plate head I Back plate head	Version 1		Version 2		Version 3	
	d _h [mm]	k [mm]	d _h [mm]	k [mm]	d _h [mm]	k [mm]
3.0; 3.4	7.2	1.5	7.8	1.5	9.0	1.4
3.5; 3.9	8.4	1.8				
4.0; 4.4	9.4	1.8				
4.5	10.0	2.7				
5.0; 5.5	12.0	2.8				
6.0; 6.3; 6.5	14.0	3.0				
6.0 ASSY plus VG	14.0	3.0				
7.0	14.0	3	17.0	3.5		
7.5; 8.0	18.9	4.0	18.9	4.2	22.1	3.8
8.0 ASSY plus VG	22.1	3.8				
10.0	25.2	4.2	25.2	4.6		
10.0 ASSY plus VG	25.2	4.6				
12.0	29.4	5.0				
12.0 ASSY plus VG	29.4	5.0				
14.0 ASSY plus VG	29.4	5.0				

Type B Disc/plate head II with and without milled edges		
d [mm]	d _h [mm]	k [mm]
3.0; 3.4	7.4	1.2
3.5; 3.9	8.3	1.4
4.0; 4.4	9.3	1.6
4.5	10.0	1.8
5.0; 5.5	11.0	1.4
6.0; 6.3; 6.5	13.5	1.6
6.0 ASSY plus VG	13.5	1.6
7.0	15.2	2.0
7.5; 8.0	18.4	2.3
8.0 ASSY plus VG	18.4	2.3
10	22.5	2.7
10.0 ASSY plus VG	22.5	2.7
12.0	26.0	3.3
14.0 ASSY plus VG	26.0	3.3

Würth self-tapping screws	Annex A.9
Dimensions	

English translation prepared by DIBt

Type C Disc/plate head III with and without milled edges	Version 1		Version 2		Version 3		Version 4	
	d _h [mm]	k [mm]	d _h [mm]	k [mm]	d _h [mm]	k [mm]	d _h [mm]	k [mm]
3.0; 3.4	7.8	0.9						
3.5; 3.9	7.8	0.9	8.4	0.9				
4.0; 4.4	8.4	0.9	9.4	1.0				
4.5	9.4	1.0	10.0	1.2				
5.0; 5.5	10.0	1.2	12.0	1.8				
6.0; 6.3; 6.5	12.0	1.8	14.0	1.8				
6.0 ASSY plus VG	14.0	1.8						
7.0	14.0	1.8	17.0	1.8				
7.5; 8.0	15.0	2.5	17.0	1.8	18.4	2.5	22.1	2.5
8.0 ASSY plus VG	15.0	2.5	18.4	2.5	22.1	2.5		
10.0	18.5	2.8	22.1	2.5	25.2	2.8	25.2	3.2
10.0 ASSY plus VG	18.5	2.8	25.2	2.8				
12.0	25.2	2.8	25.2	3.2	29.4	3.2		
12.0 ASSY plus VG	29.4	3.2						
14.0 ASSY plus VG	29.4	3.2						

Type D Flat head		
d [mm]	d _h [mm]	k [mm]
7.5; 8.0	12.2	2.8

Würth self-tapping screws	Annex A.9
Dimensions	

English translation prepared by DIBt

Type E Hinge head with and without milled edges/ shaft reinforcement	Version 1			Version 2			Version 3		
	d _h [mm]	k [mm]	d _a ± 0.5 [mm]	d _h [mm]	k [mm]	d _a ± 0.5 [mm]	d _h [mm]	k [mm]	d _a ± 0.5 [mm]
4.0; 4.4	10.0	2.4	4.0						
4.5	12.0	2.6	4.5						
5.0; 5.5	12.2	2.8	5	11.0	2.8	5.3			
6.0; 6.3; 6.5	14.5	3.2	6.0	13.5	3.3	6.0			
6.0 ASSY plus VG	14.5	3.2	6.0						
7.0	15.5	3.4	7.0						
7.5; 8.0	15.5	3.5	8.0	15.5	3.5	8.3	16.0	3.8	8.5
8.0 ASSY plus VG	15.5	3.5	8.0						
10.0	17.5	4.0	10.0						
10.0 ASSY plus VG	17.5	4.0	10.0						
12.0	18.5	4.2	12.0						
12.0 ASSY plus VG	18.5	4.2	12.0						

Type F Cylinder head	Version 1		Version 2		Version 3		Version 4		Version 5	
	d _h [mm]	k [mm]	d _h [mm]	k [mm]	d _h [mm]	k [mm]	d _h [mm]	k [mm]	d _h [mm]	k [mm]
3.0; 3.4	4.7	2.3								
3.5; 3.9	5.8	2.8								
4.0; 4.4	6.2	3.2								
4.5	5.0	2.8	5.0	3.6	5.8	2.8	6.2	3.8	6.8	2.2
5.0; 5.5	6.8	2.2	7.2	4.3						
6.0; 6.3; 6.5	8.2	4.7								
6.0 ASSY plus VG	8.2	4.7								
7.5; 8.0	7.5	4.2	8.0	4.0	10.0	7.5				
8.0 ASSY Isotop	11.1	9.0								
8.0 ASSY plus VG	10.0	7.5								
10.0	13.4	8.0								
10.0 ASSY plus VG	13.4	8.0								
12.0	14.2	9.6								
12.0 ASSY plus VG	14.2	9.6								
14.0 ASSY plus VG	14.2	9.6	18.5	10.5						

Würth self-tapping screws	Annex A.9
Dimensions	

English translation prepared by DIBt

Type G Stepped head		
d [mm]	d _h [mm]	k [mm]
5.0; 5.5	7.7	2.8

Type H Countersunk head With/without lens/milling pocket	Version 1			Version 2			Version 3			Version 4			Version 5			
	d	d _h	k	f	d _h	k	f	d _h	k	f	d _h	k	f	d _h	k	f
[mm]																
3.0; 3.4	4.9	1.3	0.5	5.9	1.9	0.6	7.0	2.3	0.6							
3.5; 3.9	5.6	2.0	0.5	5.9	1.9	0.6	7.0	2.3	0.6	8.0	2.5	0.8				
4.0; 4.4	7.0	2.3	0.6	8.0	2.5	0.8	8.9	2.8	0.9							
4.5	7.6	2.8	0.6	8.0	2.5	0.8	8.9	2.8	0.9	9.6	3.2	1.0				
5.0; 5.5	7.6	2.7	0.6	8.9	2.8	0.9	9.6	3.2	1.0	12.0	4.4	1.1				
6.0; 6.3; 6.5	9.6	3.2	1.0	12.0	4.4	1.1	13.7	4.7	1.3							
6.0 ASSY plus VG	9.6	3.2	1.0	12.0	4.4	1.1	13.7	4.7	1.3							
7.0	12.0	4.4	1.1	13.7	4.7	1.3	15.0	4.9	1.3							
7.5; 8.0	13.7	4.7	1.3	15.0	4.9	1.3	18.5	5.8	1.8							
8.0 ASSY plus VG	12.0	4.4	1.1	13.7	4.7	1.3	15.0	4.9	1.3	18.5	5.8	1.8	20.0	6.5	1.8	
10.0	15.0	4.9	1.3	18.5	5.8	1.8	22.5	7.0	1.8							
10.0 ASSY plus VG	15.0	4.9	1.3	18.5	5.8	1.8	20.0	6.5	1.8	22.5	7.0	1.8				
12.0	18.5	5.8	1.8	22.5	7.0	1.8	24.0	7.3	1.8							
12.0 ASSY plus VG	18.5	5.8	1.8	20	6.5	1.8	22.5	7.0	1.8	24.0	7.5	1.9				
14.0 ASSY plus VG	22.5	7.0	1.8	24.0	7.5	1.9										

Würth self-tapping screws	Annex A.9
Dimensions	

English translation prepared by DIBt

Type I Countersunk head with milled edges, with and without lens/high collar	Version 1			Version 2			Version 3			Version 4			
	d	d _h	k	f	d _h	k	f	d _h	k	f	d _h	k	f
	[mm]												
3.0; 3.4	4.9	2.0	0.5	5.9	2.4	0.6	7.0	2.8	0.6				
3.5; 3.9	5.9	2.4	0.6	7.0	2.8	0.6	8.0	3.4	0.8				
4.0; 4.4	7.0	2.8	0.6	8.0	3.4	0.8	8.9	3.8	0.9				
4.5	8.0	3.4	0.8	8.9	3.8	0.9	10.0	4.4	1.0				
5.0; 5.5	7.2	2.0	-	8.9	3.8	0.9	10.0	4.4	1.0	12.0	5.6	1.1	
6.0; 6.3; 6.5	10.0	4.4	1.0	12.0	5.6	1.1	13.7	5.9	1.2				
6.0 ASSY plus VG	12.0	5.7	1.2										
7.0	12.0	5.6	1.1	13.7	5.9	1.2	15.0	6.5	1.2				
7.5; 8.0	12.0	3.6	1.2	13.7	5.9	1.2	15.0	6.5	1.2	18.5	7.6	1.8	
8.0 ASSY plus VG	15.0	7.0	1.2										
10.0	15.0	6.5	1.2	18.5	7.6	1.8	22.5	9.8	1.8				
10.0 ASSY plus VG	18.5	8.6	1.8										
12.0	18.5	7.6	1.8	22.5	9.8	1.8	24.0	10.3	1.8				

Type J Wood construction head with milled edges and high collar	Version 1		Version 2		
	d [mm]	d _h [mm]	k [mm]	d _h [mm]	k [mm]
4.5	8.2	5.8	8.2	4.2	
5	9.4	6.1	9.4	4.7	
6	10.4	6.5	10.4	4.8	
8	13.4	7.3			
10	16.4	7.7			

Type K Countersunk head 75° with and without lens/milling edges			
	d [mm]	d _h [mm]	k [mm]
3.0; 3.4	5.8	2.8	
3.5; 3.9	7.0	3.3	
4.0; 4.4	7	3.1	

Würth self-tapping screws	Annex A.9
Dimensions	

English translation prepared by DIBt

Type L Wood construction head 60° with and without lens	Version 1			Version 2		
	d [mm]	d _h [mm]	k [mm]	f [mm]	d _h [mm]	k [mm]
3.0; 3.4	5.0	2.8	0.35			
3.5; 3.9	5.5	3.0	0.5	6.0	3.4	0.5
4.0; 4.4	7.0	4.2	0.6	7.0	3.9	-
4.5	7.0	3.8	0.6	7.3	3.9	0.6
5.0; 5.5	10	5.7	0.8	7.6	4.0	-
6.0; 6.5	10.0	4.8	-	10.0	5.6	-

Type M Countersunk head with head hole		
	d [mm]	d _{s1} [mm]
4.0; 4.4	3.6	8.0
4.5	3.9	8.0
5.0; 5.5	3.9	8
6.0; 6.3; 6.5	4.6	8.0

Type N Top Head with and without lens				
	d [mm]	d _h [mm]	k [mm]	f [mm]
3.0; 3.4	5.25	3.2	0.35	4.05
3.5; 3.9	5.5	3.4	0.4	4.3
4.0; 4.4	7.0	3.8	0.6	5.5
4.5	7.2	3.7	0.6	5.7
5.0; 5.5	8.0	4.7	0.6	6.1

Würth self-tapping screws	Annex A.9
Dimensions	

English translation prepared by DIBt

Type O Top Head II with and without lens				
d [mm]	d _h [mm]	k [mm]	f [mm]	d _a ± 0.4 [mm]
3.0; 3.4	5.25	3.5	0.35	4.15
3.5; 3.9	6.0	3.5	0.5	4.5
4.0; 4.4	7.0	4.2	0.6	5.6
4.5	7.7	4.2	0.7	6.2
5.0; 5.5	8.5	5.0	0.7	6.6

Type P FBS head with and without lens		
d [mm]	d _h [mm]	k [mm]
3.5; 3.9	7.2	2.8
4.0; 4.4	7.2	2.5
4.5	7.2	2.3

Type Q Spengler head with and without lens			
d [mm]	d _h [mm]	k [mm]	f [mm]
4.5; 5.0; 5.5	8.2	2.3	0.7

Type R Jam head							
d [mm]	d _h [mm]	k [mm]	l _{R1} [mm]	l _{R2} [mm]	d _R [mm]	d _S [mm]	P _R [mm]
6.0 Jamo I	12.3	3.5	19.0	22.0	9.9	7.4	3.5
6.0 Jamo II	12.0	4.3	21.0	23.2	6.7	4.0	3.5

Würth self-tapping screws	Annex A.9
Dimensions	

English translation prepared by DIBt

Type S Pan head	Version 1		Version 2		Version 3		Version 4		Version 5	
d [mm]	d _h [mm]	k [mm]	d _h [mm]	k [mm]	d _h [mm]	k [mm]	d _h [mm]	k [mm]	d _h [mm]	k [mm]
3.0; 3.4	5.0	2.2	5.8	2.2	7.0	2.4				
3.5; 3.9	5.8	2.2	7.0	2.4	7.9	2.2				
4.0; 4.4	7.0	2.4	7.9	2.2	7.9	2.8	9.0	3.0		
4.5	7.9	2.2	9.0	3.0	10.0	3.6				
5.0; 5.5	9.0	3.0	10	3.6	12.0	4.0				
6.0; 6.3; 6.5	9.0	3.0	10.0	3.6	12.0	4.2	13.7	4.3		
7.0	12.0	4.0	13.7	4.3	14.5	5.1				
7.5; 8.0	12.2	2.8	13.7	4.3	14.5	5.1	15.8	5.1	18.6	5.5
10.0	15.8	5.1	18.6	5.5	18.8	6.6	21.5	6.0		
12.0	18.6	5.5	18.8	6.6	21.5	6.0	21.5	7.6		

Type T Elmo head		
d [mm]	d _h [mm]	k [mm]
4.0; 4.4	8.0	2.8
4.5	9.0	3.0
5.0; 5.5	10.0	3.6
6.0; 6.3; 6.5	12.0	4.0

Type U Beam shoe head		
d [mm]	d _h [mm]	k [mm]
5.0	8.0	2.6

Type V Hexagon head with and without shaft reinforcement/washer			
d [mm]	d _c [mm]	k [mm]	d _g ± 0.5 [mm]
5.0; 5.5	11.8	5.0	5.0
6.0; 6.3; 6.5	14.2	5.8	6.0
7.0	15.9	6.2	7.0
7.5; 8.0	18.0	6.6	8
10	21.2	7.4	10.0
12.0	25.3	8.2	12.0

Würth self-tapping screws	Annex A.9
Würth self-tapping screws Dimensions	

English translation prepared by DIBt

Type W Combination head with and without shaft reinforcement with and without flange	Version 1				Version 2					
	d	SW	k	da ± 0.5	la ± 0.8	SW	k	da ± 0.2	la ± 0.8	dc ± 0.5
[mm]										
6.0; 6.3; 6.5	9.0	3.0	6.0	2.0						
6.0 ASSY plus VG	9.0	3.0	6.0	2.0						
7.5; 8.0	12.0	4.5	8.0	2.8	12	4.5	7.9	—	15	
8.0 ASSY plus VG	12.0	4.5	8.0	2.8						
10	15/17	5.0	10.0	3.0	15	5	9.9	—	18.5	
10.0 ASSY plus VG	15/17	5.0	10.0	3	17	5.5	11.8	3.0	—	
12.0	17/19	5.5	12.0	3.2						
12.0 ASSY plus VG	17	5.5	12.0	3.2						
14.0 ASSY plus VG	17	6.0	14.0	3.4	19/21	7.0	16.0	4.5	—	

Type X External hexagonal head with and without washer	Version 1		Version 2		Version 3		
	d [mm]	d _h [mm]	k [mm]	d _h [mm]	k [mm]	d _h [mm]	k [mm]
5.0; 5.5		6.0	4.2	10.0	4.2		
6.0; 6.3; 6.5		8.0	5.0	11.0	5.0		
6.0 ASSY plus VG		8.0	4.5	11.0	4.5		
7.0		10.0	7.0	13.0	7.0		
7.5; 8.0		10	7.0	13.0	7		
8.0 ASSY plus VG		10.0	7.0	13.0	7.0		
10		13.0	8.0	17.0	8.0		
10.0 ASSY plus VG		13.0	8.0	17.0	8.0	17.0	10.0
12.0		13.0	9.0	18.0	9.0		
12.0 ASSY plus VG		13.0	9.0	18.0	9.0		
14.0 ASSY plus VG		18.0	10	22.0	11.0		

Würth self-tapping screws	Annex A.9
Dimensions	

English translation prepared by DIBt

Type Y Threaded bolt head with and without hexagon	
d [mm]	D [mm]
6.0; 6.3; 6.5	M6
7.0	M6
8.0 ASSY plus VG	M6; M8
10.0	M8; M10
10.0 ASSY plus VG	M8; M10
12.0	M10

Type Z Flat head with hexagon		
d [mm]	d _h [mm]	k [mm]
6.0	14	2

Würth self-tapping screws	Annex A.9
Dimensions	

English translation prepared by DIBt

A.9.3 Screw shaft and end mill

Screw shank						
d [mm]	d _s ASSY Version 1 [mm]	d _s ASSY Version 2 [mm]	d _s ASSY plus [mm]	d _s ASSY stainless steel Version 1 [mm]	d _s ASSY stainless steel Version 2 [mm]	d _s ASSY plus stainless steel [mm]
3.0	2.2		2.3	2.2		2.3
3.4	2.2		2.3	2.2		2.3
3.5	2.6		2.6	2.6		2.8
3.9	2.6		2.6	2.6		2.6
4.0	2.85		2.85	2.85	3.2	3.0
4.4	2.85		2.85	2.85		2.8
4.5	3.2		3.2	3.2	3.5	3.5
5.0	3.6		3.6	3.6	4.0	
5.5				4.3		4.0
6.0	4.4		4.4	4.4		
6.3	3.9			3.9		
6.5						5.0
7.0	5.0					
8.0	5.8	6.5	5.8	5.95	5.8	5.9
10.0	7.2			7.2		
12.0	8.2					

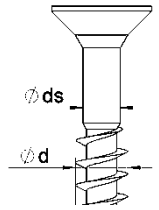

Additional shaft grooves may be present on the screw shaft. The shaft grooves may also be designed as threads or counter threads. Shaft grooves or corresponding threads with the same shape may be arranged over the entire shaft or part of it. Shaft grooves may be designed as follows, for example.

End mill

d [mm]	Type A		Type B		Type C
	d _{sf} [mm]	l _{sf} [mm]	d _{sf} [mm]	l _{sf} [mm]	d _{sf} [mm]
5.0	4.0	8.2	4.0	5-10	4.2
5.5	4.5	8.2	4.5	5-10	
6.0	5.0	10.2	4.8	6-12	4.9
6.5	5.7	10.2	5.6	7-14	
7.0	6.0	10.2	5.6	7-14	5.5
7.5	7.1	10.2	6.3	8-16	6.6
8.0	7.1	10.2	6.3	8-16	6.6
10.0	8.6	10.2	7.9	10-20	8.0
12.0	9.8	14.2	9.0	12-24	9.1

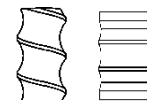

Würth self-tapping screws	Annex A.9
Dimensions	

English translation prepared by DIBt

A.9.4 Screw threads

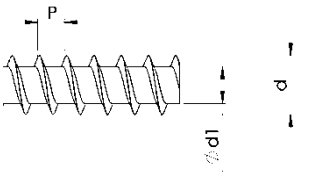
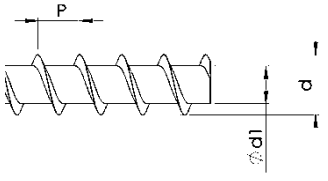
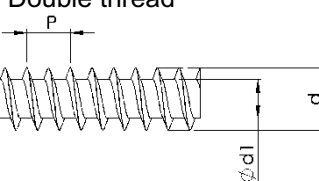
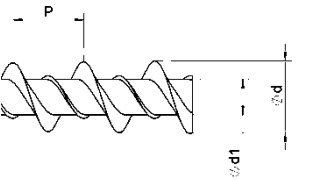
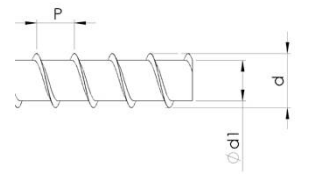
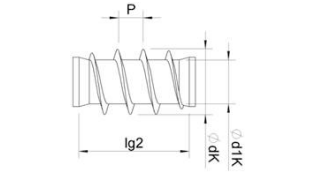
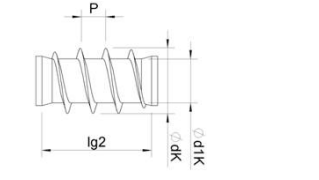
<p>Thread type A</p>  <p>Input thread</p>	<p>Thread type B</p>  <p>Coarse thread</p>	<p>Thread type C Double thread</p> 	<p>Thread type D</p>  <p>WG-Fix thread</p>
<p>Thread type E UHP thread</p> 	<p>Thread type F Underhead thread type PII</p> 	<p>Thread type G Underhead thread type P</p> 	

Würth self-tapping screws	Annex A.9
Dimensions	

English translation prepared by DIBt

Type A Inlet thread	Carbon steel			Stainless steel Version 1			Stainless steel Version 2		
	d ₁ [mm]	d [mm]	p [mm]	d ₁ [mm]	d [mm]	p [mm]	d ₁ [mm]	d [mm]	p [mm]
3.0 ASSY	1.95	3.0	1.35	1.95	3.0	1.35			
3.0 ASSY plus/plus special/plus centring tip	2.05	3	1.35; 1.9	2.0	3.0	1.35			
3.4 ASSY & ASSY plus	1.8	3.4	1.8						
3.5 ASSY	2.1	3.5	1.6	2.1	3.5	1.6			
3.5 ASSY plus/plus special/plus centring tip	2.1	3.5	1.6; 2.2	2.5	3.5	1.6			
3.9 ASSY & ASSY plus	2.0	3.9	2.0						
4.0 ASSY	2.5	4.0	1.8	2.5	4.0	1.8	3.0	4.0	1.8
4.0 ASSY plus/plus special/plus centring tip	2.5	4.0	1.8; 2.6	2.65	4.0	1.8			
4.4 ASSY & ASSY plus	2.3	4.4	2.2						
4.5 ASSY	2.7	4.5	2.0	2.7	4.5	2.0	3.2	4.5	2.0
4.5 ASSY plus/plus special/plus centring tip	2.7	4.5	2.0; 2.8	3.1	4.5	2.0	3.1	4.5	2.8
5.0 ASSY	3.15	5.0	2.2	3.15	5.0	2.2			
5.0 ASSY plus/plus special/plus centring tip	3.2	5.0	1.35; 1.9						
5.5 ASSY plus/plus special/plus centring tip				3.9	5.5	2.2			
6.0 ASSY	3.9	6.0	2.6	3.9	6.0	2.6			
6.0 ASSY plus/plus special/plus centring tip	3.9	6	2.6; 3.2; 3.6						
6.0 ASSY plus VG	3.8	6	2.6						
6.5 ASSY plus/plus special/plus centring tip				4.7	6.5	2.2			
8.0 ASSY	5.0	8.0	3.7	5.0	8.0	3.6			
8.0 ASSY plus/plus special/plus centring tip				5.1	8.0	3.6			
8.0 ASSY plus VG	5.0	8.0	3.7						
10.0 ASSY	6.2	10.0	4.4	6.0	10.0	4.4			
10.0 ASSY plus VG	6.2	10.0	4.4						
12.0 ASSY	7.1	12	6.0						
12.0 ASSY plus VG	7.1	12	6.0						
14.0 ASSY plus VG	8.5	14	6.8						

Würth self-tapping screws	Annex A.9
Dimensions	

English translation prepared by DIBt

Type B Coarse thread	Carbon steel			Stainless steel Version 1			Stainless steel Version 2		
	d ₁ [mm]	d [mm]	p [mm]	d ₁ [mm]	d [mm]	p [mm]	d ₁ [mm]	d [mm]	p [mm]
3.0	2.0	3.0	1.9	2.0	3.0	1.9			
3.5	2.1	3.5	2.2	2.1	3.5	2.2	2.5	3.5	2.2
4.0	2.5	4.0	2.6	2.5	4.0	2.6	2.7	4	2.6
4.5	2.7	4.5	2.8	2.7	4.5	2.8	3.1	4.5	2.8
5.0	3.2	5.0	3.1	3.2	5.0	3.1			
5.5				3.5	5.5	3.1			
6.0	3.9	6.0	3.6	3.9	6.0	3.6			
6.5				4.7	6.5	3.6			
7.0	4.2	7.0	4.6						
8.0	5.3	8.0	5.6	5.3	8.0	5.6			
10.0	6.5	10.0	6.6	6.3	10.0	6.6			
12.0	7.5	12.0	6.6						

Type C Double pitch thread			
d [mm]	d ₁ [mm]	d [mm]	p [mm]
3.0 ASSY	1.95	3.0	2.7
3.5 ASSY	2.1	3.5	3.2
4.0 ASSY	2.5	4.0	3.6
4.5 ASSY	2.7	4.5	4.0
5.0 ASSY	3.15	5.0	4.4
6.0 ASSY	3.9	6.0	5.2

Type D WG-Fix thread			
d [mm]	d ₁ [mm]	d [mm]	p [mm]
6.3 WG-Fix	3.2	6.3	6.4

Type E UHP thread			
d [mm]	d ₁ [mm]	d [mm]	p [mm]
8.0 ASSY	6.15	8.0	4.0

Type F Underhead thread Type PII with $l_{g2} < 4 \cdot d$	Version 1			Version 2		
	d _{1K} [mm]	d _K [mm]	p [mm]	d _{1K} [mm]	d _K [mm]	p [mm]
8.0	5.3	8.0	5.6	5.0	8.0	3.6

Würth self-tapping screws	Annex A.9
Dimensions	

English translation prepared by DIBt

Type G Underhead thread Type P with $l_{g2} < 4 \cdot d$				
d [mm]	d_{1K} [mm]	d_K [mm]	p [mm]	l_{g2} [mm]
3.0; 3.4	2.1	3.5	1.35	6.0
3.5; 3.9	2.5	4.0	1.6	6.5
4.0; 4.4	2.5	4.7	1.8	6.5
4.5	2.85	5.0	2.0	7.5
5.0; 5.5	3.9	6.0	2.2	8.5
6.0; 6.3; 6.5	4.5	7.0	2.6	11.0
7.0	4.9	8.0	3.3	12.5
7.5; 8.0	5.7	9.0	4.0	14.5
10.0	6.5	11.0	5.0	20.5
12.0	7.2	13.0	5.0	22.0

Würth self-tapping screws	Annex A.9
Dimensions	

English translation prepared by DIBt

A.9.5 Screw tip

Screw tips can have different milling elements, such as tip types A to F.

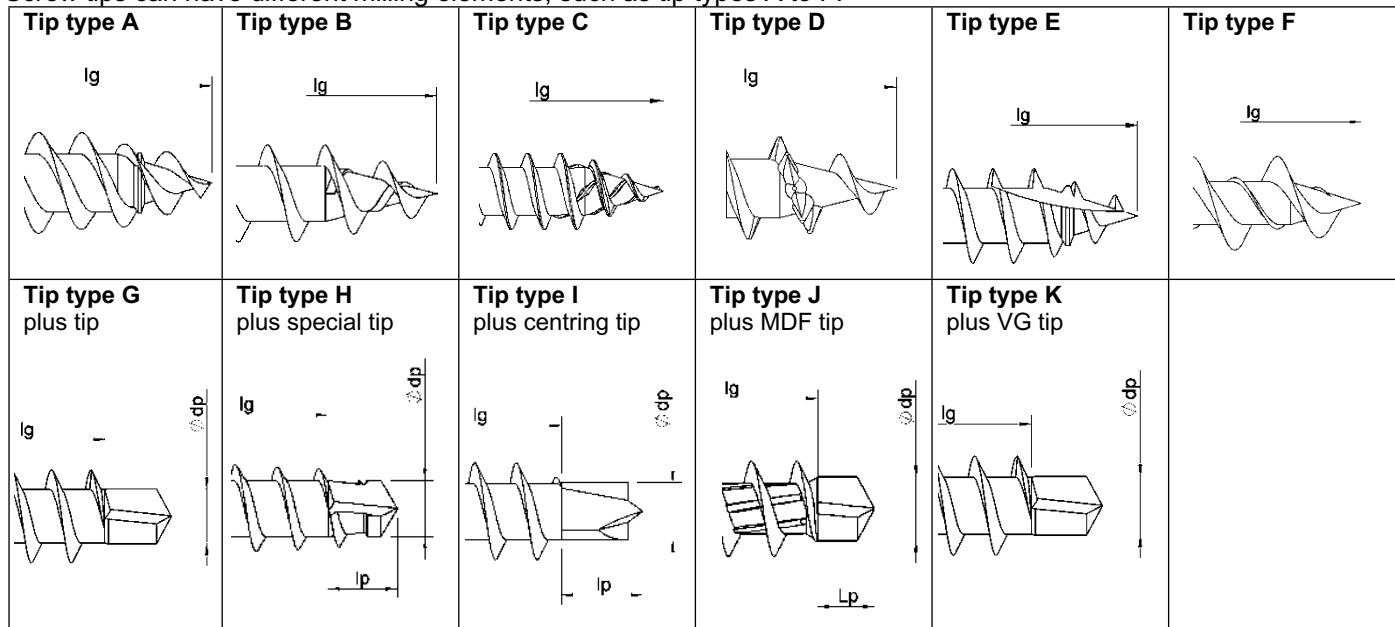

d [mm]	Type G plus lace		Type H plus special tip		Type I plus centring tip		Type J plus MDF tip		Type K plus VG tip
	lp [mm]	dp [mm]	lp [mm]	dp [mm]	lp [mm]	dp [mm]	lp [mm]	dp [mm]	dp [mm]
3.0	3.0	2.24	3.0	2.24	3.0	2.24			
3.4							2.3 ≤ lp ≤ 4.0	2.7	
3.5	3.0	2.24	3.0	2.24	3.0	2.24			
3.5 Stainless steel	3.0	2.7	3.0	2.7	3	2.7			
3.9							2.3 ≤ lp ≤ 4.0	2.7	
4.0	3.2	2.7	3.2	2.65	3.2	2.7			
4.0 Stainless steel	3.2	2.9	3.2	2.85	3.2	2.9			
4.4							2.3 ≤ lp ≤ 4.0	3.0	
4.5	3.5	3.2	3.5	3.15	3.5	3.2			
5.0	4.2	3.2	4.2	3.15	4.2	3.2			
5.5	4.2	3.9	4.2	3.85	4.2	3.9			
6.0	4.5	3.9	4.5	3.85	4.5	3.9			3.8
6.5	4.5	4.9	4.5	4.85	4.5	4.9			
8.0	5.0	6.0	5.0	5.95	5.0	6.0			5.0
10.0									6.2
12.0									7.1
14.0									8.5

Würth self-tapping screws	Annex A.9
Dimensions	

English translation prepared by DIBt

A.9.6 Bolt marking

Lieferantencodierung
code for supplier

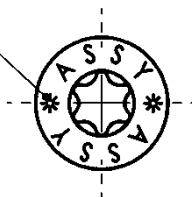

Lieferantencodierung
code for supplier

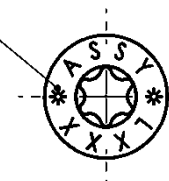

Marking for ASSY d = 3-6 mm of the following types: countersunk heads, combination heads, pan heads and disc/plate heads. The head shapes mentioned are also available without marking.

Marking for ASSY d = 7-14 mm versions: Countersunk heads, hinge, combination, pan head and disc/plate head. The head shapes mentioned are also available without lettering.

ASSY transport anchor screw:

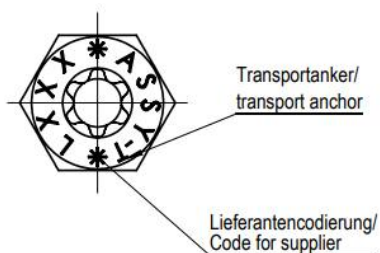

Würth self-tapping screws	Annex A.9
Dimensions	

English translation prepared by DIBt

A.9.7 Countersunk and washers

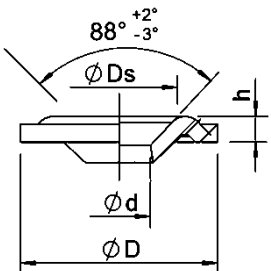
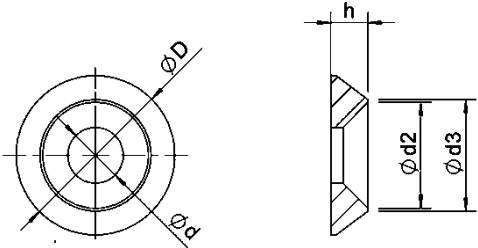
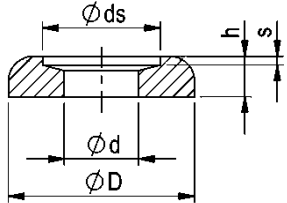
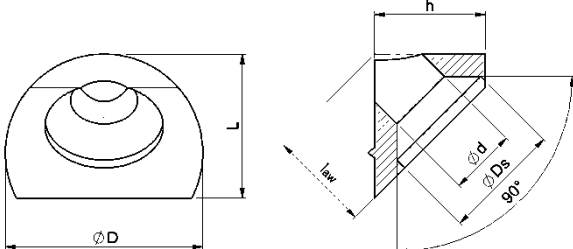
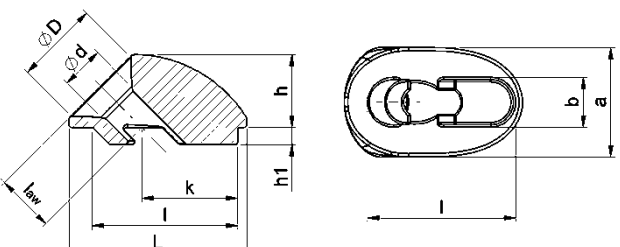
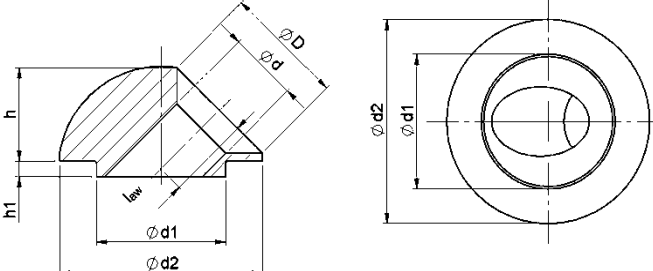
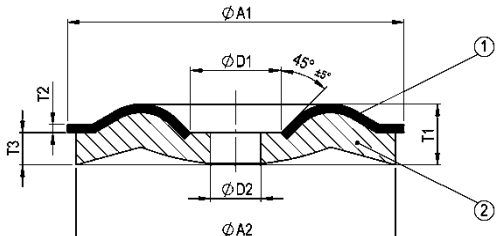
<p>Washer type A</p> 	<p>Washer type B</p> 
<p>Disc type C</p> 	<p>Disc type D</p> 
<p>Disc type E</p> 	<p>Disc type F</p> 
<p>Washer type G</p> 	

Washer/countersunk washers: Material: galvanised steel and stainless steel with the following possible surfaces: bright, brass-plated, nickel-plated, burnished, electro-galvanised, blue passivated, yellow chromated, black chromated, zinc-nickel, zinc-nickel passivated, zinc flake, Ruspert, fully or partially painted, hot-dip galvanised, aluminium coating, phosphated, HCP coating or Delta coating. The surface coatings can be combined with each other.

<p>Würth self-tapping screws</p>	<p>Annex A.9</p>
<p>Dimensions</p>	

English translation prepared by DIBt

Type A Pressed countersunk washer Steel, aluminium or stainless steel				
Size	D [mm]	d [mm]	h [mm]	Ds [mm]
6	22 ± 0.5	6.5 ± 0.5	3.0 ± 0.5	13.0 ± 1.0
8	28 ± 0.5	8.5 ± 0.5	3.5 ± 0.5	16.0 ± 1.0
10	33 ± 0.5	10.5 ± 0.5	4.3 ± 0.5	19.5 ± 1.0
12	42 ± 0.5	12.5 ± 0.5	5.0 ± 0.5	23.0 ± 1.0

Type B Countersunk washer, turned Steel or aluminium					
Size	d [mm]	D [mm]	h [mm]	d2 [mm]	d3 [mm]
6	6.4 ± 0.2	22.0 ± 0.5	4.5 ± 0.3	14.0 ± 0.3	15.0 ± 0.3
8	8.4 ± 0.2	25.0 ± 0.5	5.0 ± 0.3	17.0 ± 0.3	18.0 ± 0.3
10	10.4 ± 0.2	30.0 ± 0.5	7.0 ± 0.3	20.0 ± 0.3	21.0 ± 0.3
12	12.4 ± 0.2	40.0 ± 0.5	8.5 ± 0.3	23.0 ± 0.3	24.0 ± 0.3
Stainless steel					
6	6.4 ± 0.2	22.0 ± 0.5	3.8 ± 0.3	14.0 ± 0.3	14.5 ± 0.3
8	8.4 ± 0.2	25.0 ± 0.5	5.0 ± 0.3	18.4 ± 0.3	19.0 ± 0.3
10	10.4 ± 0.2	30.0 ± 0.5	7.0 ± 0.3	20.0 ± 0.3	21.0 ± 0.3

Type C Washer for disc/plate head II Steel or stainless steel					
Size	d [mm]	D [mm]	h [mm]	s [mm]	ds [mm]
5	9.0 ± 0.4	15.0 ± 0.5	3.5 ± 0.3	1.0 ± 0.2	11.7 ± 0.5
6	11.0 ± 0.4	22.0 ± 0.5	5.0 ± 0.3	1.1 ± 0.2	14.5 ± 0.5
7	12.0 ± 0.4	25.0 ± 0.5	5.5 ± 0.3	1.4 ± 0.2	16.2 ± 0.5
8	12.0 ± 0.4	30.0 ± 0.5	6.5 ± 0.3	1.4 ± 0.2	19.0 ± 0.5
12	17.0 ± 0.4	42.0 ± 0.5	8.5 ± 0.3	1.9 ± 0.2	27.5 ± 0.5

Würth self-tapping screws	Annex A.9
Dimensions	

English translation prepared by DIBt

Type D 45° angle bracket for wood-to-wood fastening Steel or stainless steel						
Size	d [mm]	D [mm]	Ds [mm]	h [mm]	L [mm]	l _{aw} [mm]
8	8.5 ± 0.3	25.0 ± 0.5	15.9 ± 0.3	14.0 ± 0.5	18.2 ± 0.5	12.9 ± 0.5

Type E 45° angle bracket for steel-wood fastening Cast steel or cast stainless steel										
Size	d [mm]	D [mm]	L [mm]	a [mm]	h [mm]	h1 [mm]	b [mm]	l [mm]	k [mm]	l _{aw} [mm]
6	6.5 ± 0.3	14.5 ± 0.5	20.5 ± 1.0	17.0 ± 0.5	13.5 ± 0.8	2.7 ± 0.4	6.9 ± 0.2	22.7 ± 0.3	13.5 ± 0.3	10.7 ± 0.5
8	8.5 ± 0.3	19.0 ± 0.5	39.0 ± 1.0	24.0 ± 0.5	16.0 ± 0.8	3.7 ± 0.4	9.9 ± 0.2	31.7 ± 0.3	21.0 ± 0.3	12.7 ± 0.5
10	10.7 ± 0.3	24.0 ± 0.5	52.0 ± 1.0	29.0 ± 0.5	21.4 ± 0.8	4.7 ± 0.4	10.8 ± 0.2	43.7 ± 0.3	28.7 ± 0.3	18.4 ± 0.5
12	12.7 ± 0.3	26.0 ± 0.5	59.0 ± 1.0	30.0 ± 0.5	23.5 ± 0.8	5.6 ± 0.4	12.8 ± 0.2	49.7 ± 0.3	34.0 ± 0.3	19.8 ± 0.5

Type F 45° angle bracket for steel-wood fastening Steel or stainless steel							
Size	d [mm]	D [mm]	d1 [mm]	d2 [mm]	h [mm]	h1 [mm]	l _{aw} [mm]
6	6.5 ± 0.3	12.0 ± 0.5	12.9 ± 0.2	20.0 ± 0.5	10.0 ± 0.8	1.9 ± 0.3	8.0 ± 0.5
8	8.5 ± 0.3	15.0 ± 0.5	15.9 ± 0.2	25.0 ± 0.5	11.6 ± 0.8	1.9 ± 0.3	9.5 ± 0.5

Type G Washer for sheet metal screw Material 1: stainless steel or copper Material 2: EPDM (seal; not part of the ETA)							
Size	A1 [mm]	A2 [mm]	D1 [mm]	D2 [mm]	T1 [mm]	T2 [mm]	T3 [mm]
15	15.0 ± 0.5	14.0 ± 0.6	5.4 ± 0.6	3.0 ± 0.5	3.0 ± 0.6	0.5 ± 0.2	1.9 ± 0.5
20	20.0 ± 0.5	19.0 ± 0.6	5.4 ± 0.6	3.0 ± 0.5	3.4 ± 0.6	0.5 ± 0.2	1.9 ± 0.5
25	25.0 ± 0.5	24.0 ± 0.6	5.4 ± 0.6	3.0 ± 0.5	3.8 ± 0.6	0.5 ± 0.2	1.9 ± 0.5

Würth self-tapping screws	Annex A.9
Dimensions	